

REVISIONS			
REV	DESCRIPTION	DATE	BY

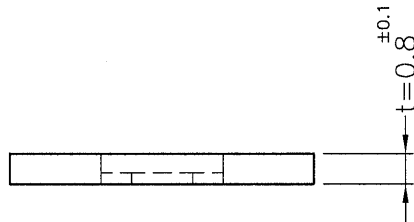
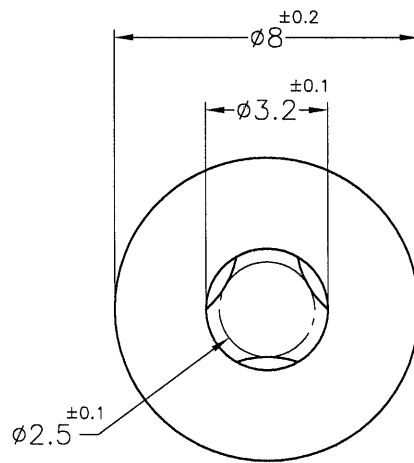
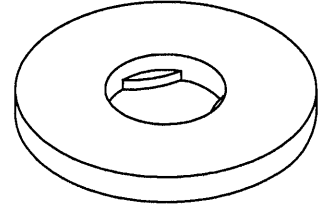

NOTE:MADE OF EQUIVALENT MATERIAL.
均可使用同等材質.

<p>康揚企業股份有限公司 KANG YANG HARDWARE ENTERPRISE CO., LTD. 康揚塑膠(東莞)有限公司 KANG YANG PLASTIC(DONG GUAN)CO.,LTD. 康哲電腦配件(吳江)有限公司 KANG CHE COMPUTER COMPONENTS(WUJIANG) CO.,LTD.</p>				TITLE	SCREW WASHER	SPEC. DWG.	
				MATERIAL	HDPE	DATE	2018.03.20
				FINISH		DRAWN	C. S. L
				COLOR	NATURAL	CHECK	
PART NUMBER	DRAWING NUMBER		UNLESS OTHERWISE SPECIFIED TOLERANCE		APPROVED		
KWS3-0.8HDPE	KWS3-0.8HDPE		SEE ABOVE				
SIZE	SCALE	UNIT	REV				
A4	5:1	mm	A				