

DIM.	TOL.
5mm DOWN	±0.2
5~20mm	±0.3
20~40mm	±0.4
40~60mm	±0.5
60~100mm	±0.8
100mm UP	±1.0

REVISIONS			
REV	DESCRIPTION	DATE	BY

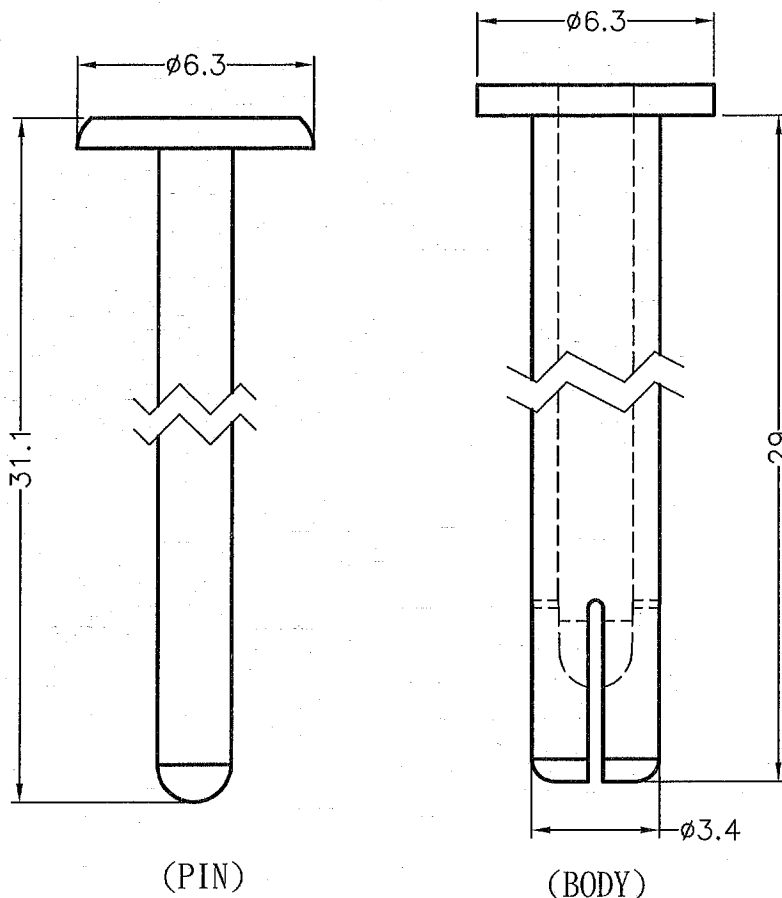

(PIN) (BODY)

MOUNTING HOLE:  $\phi 3.5$

Component - Plastics E41938

E I DUPONT DE NEMOURS & CO INC  
 ENGINEERING POLYMERS, CHESTNUT RUN PLAZA, PO BOX 80713, WILMINGTON DE 19860  
 101(r9)(f1), 101F(r9)(f1), 101L(r9)(f1), E101(r9)(f1), E101L(r9)(f1)  
 Polyamide 66 (PA66), "Zytel", furnished as pellets

Color	Min Thk (mm)	Flame Class	HVI	HAI	RTI Elec	RTI Imp	RTI Str
ALL	0.71	V-2	4	0	130	75	85
	1.6	V-2	3	0	130	75	85
	3.0	V-2	2	0	130	75	85
	6.0	V-2	2	0	130	75	85

Comparative Tracking Index (CTI): 0  
 Dielectric Strength (kV/mm): 13  
 High-Voltage Arc Tracking Rate (HVTR): 0  
 Dimensional Stability (%): -  
 (f1) - Suitable for outdoor use with respect to exposure to Ultraviolet Light, Water Exposure and Immersion in accordance with UL 746C.

NOTE - (1) Material designations that are color pigmented may be followed by suffix letters and numbers. (2) Material designations may be prefixed by "ZYT" for Zytel or "MIN" for Minlon or "DEL" for Delrin or "CRA" for Crastin or "RYN" for Rynite or "ETPV" for ETPV grades.  
 r9 - Virgin and reground up to 50% by weight inclusive, have the same basic material characteristics for ALL colors down to 0.27mm. For thickness 0.40mm to 0.70mm the same basic material characteristics exist with the exception of generic RTIs for all properties and Regrind exceeding 25% is limited to V-2 Flammability for WT, RD, BK.  
 ANSILUL 94 small-scale test data does not pertain to building materials, furnishings and related contents. ANSILUL 64 small-scale test data is intended solely for determining the flammability of plastic materials used in the components and parts of end-product devices and appliances, where the acceptability of the combination is determined by UL.

Report Date: 1988-07-29  
 Last Revised: 2010-07-27  
 © 2011 Underwriters Laboratories Inc. CULUS

NOTE: NYLON 66 UL94V-2 or EQUIVALENT

 康揚企業股份有限公司 KANG YANG HARDWARE ENTERPRISE CO., LTD. 康揚塑膠(東莞)有限公司 KANG YANG PLASTIC(DONG GUAN) CO., LTD. 康哲電腦配件(吳江)有限公司 KANG CHE COMPUTER COMPONENTS(WUJIANG) CO., LTD.	TITLE		SNAP RIVET		SPEC. DWG.		
	MATERIAL		NYLON 66 UL94V-2		DATE		2013.11.25
	FINISH		BLACK		DRAWN		C.S.L
	COLOR		SEE ABOVE		CHECK		
PART NUMBER	DRAWING NUMBER		UNLESS OTHERWISE SPECIFIED		APPROVED		 Kang
SRF3.5-29	SRF3.5-29		TOLERANCE		SEE ABOVE		
SIZE	SCALE	UNIT	REV				
A4	5:1	mm	A				