

HOLE IN P.C.B ϕ 3.5
P.C.B THICKNESS 0.8mm

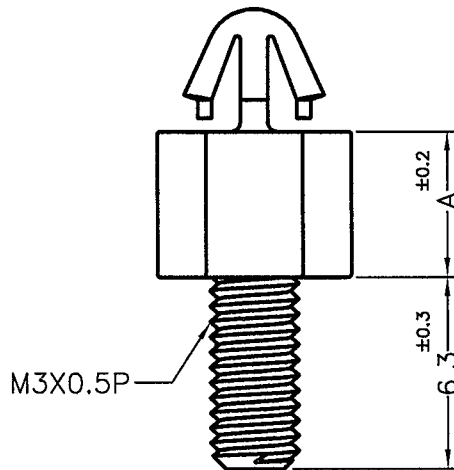

PART NO.	A
SCBC-3(B)	3.0
SCBC-5.5(B)	5.5

- NOTE:1. SHRINKING IS NORMAL STATUS.
內縮為正常現象。
2. MADE OF EQUIVALENT MATERIAL.
均可使用同等材質。
3. THE COLOR BATCH TEST REPORT IS ONLY FOR TEST PURPOSE.
色母環保檢測報告, 僅提供原始測試報告。

K
ISO 9001
ISO 14001
QC 080000
IATF 16949

康揚企業股份有限公司
KANG YANG HARDWARE ENTERPRISE CO., LTD.
康揚塑膠(東莞)有限公司
KANG YANG PLASTIC(DONG GUAN)CO.,LTD.
康哲電腦配件(吳江)有限公司
KANG CHE COMPUTER COMPONENTS(WUJIANG)CO.,LTD.

PROPRIETARY AND CONFIDENTIAL THE INFORMATION CONTAINED IN THIS DRAWING IS THE SOLE PROPERTY OF KANG YANG HARDWARE ENTERPRISE CO. ANY REPRODUCTION IN PART OR AS A WHOLE WITHOUT THE WRITTEN PERMISSION OF KANG YANG HARDWARE ENTERPRISE CO. IS PROHIBITED.	DATE	2017.08.22	TITLE	SPACER SUPPORT		DWG. NO.	PART NO.	
	DRAWN	Y.C.P	MATERIAL	NYLON 66 UL94V-2		SCBC-H(B)		SEE ABOVE
	CHECKED	<i>[Signature]</i>	COLOR	BLACK	FINISH	SIZE	SPEC. DWG.	REV
	APPROVED	<i>[Signature]</i>	UNLESS OTHERWISE SPECIFIED TOLERANCE: SEE ABOVE		A4	B		
DO NOT SCALE DRAWING					SCALE: NONE	UNIT	mm	SHEET 1 OF 1