

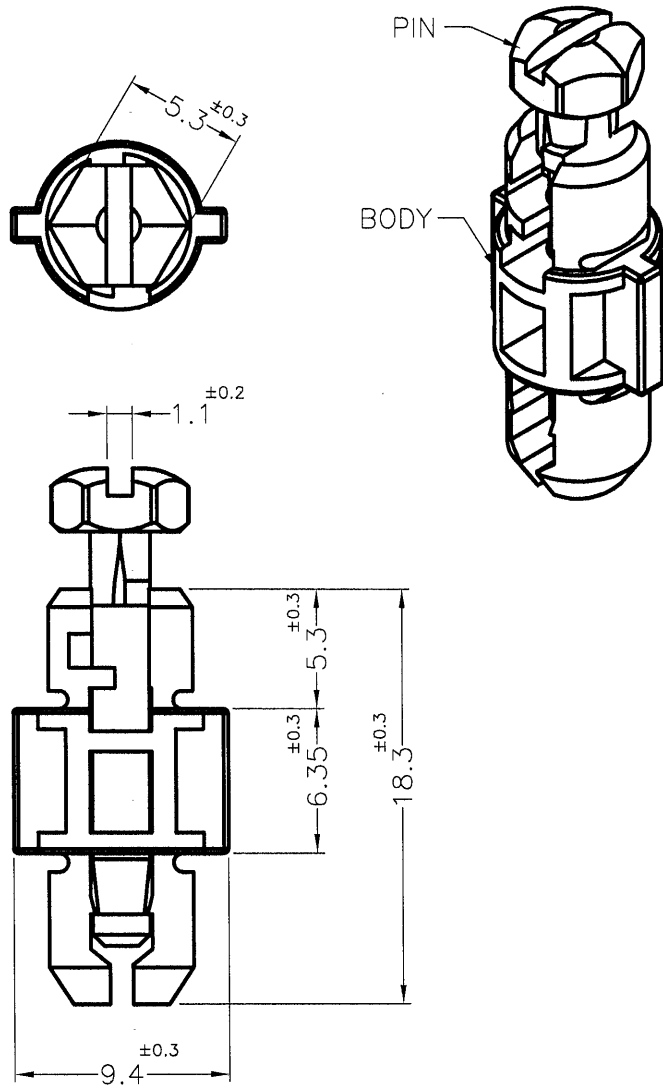

REVISIONS			
REV	DESCRIPTION	DATE	BY



MOUNTING HOLE: $\phi 6.4 \sim 6.5$ mm
 THICKNESS: 0.8~1.6mm

NOTE: MADE OF EQUIVALENT MATERIAL.
 均可使用同等材質.

 康揚企業股份有限公司 KANG YANG HARDWARE ENTERPRISE CO., LTD. 康揚塑膠(東莞)有限公司 KANG YANG PLASTIC(DONG GUAN) CO., LTD. 康哲電腦配件(吳江)有限公司 KANG CHE COMPUTER COMPONENTS(WUJIANG) CO., LTD.		TITLE	SPEC. DWG.
		SPACER SUPPORT	
PART NUMBER		BODY MATERIAL	DATE
SCMB-6.3		PC UL94V-2	2004.01.16
DRAWING NUMBER		PIN MATERIAL	DRAWN
SCMB-6.3		NYLON 66 UL94V-2	Linda
SIZE		COLOR	CHECK
A4	SCALE 3:1	BLACK	
UNIT mm	REV A	UNLESS OTHERWISE SPECIFIED TOLERANCE SEE ABOVE	APPROVED
			