

DIM.	TOL
5mmDOWN	±0.2
5~20mm	±0.3
20~40mm	±0.4
40~60mm	±0.5
60~100mm	±0.8
100mmUP	±1.0

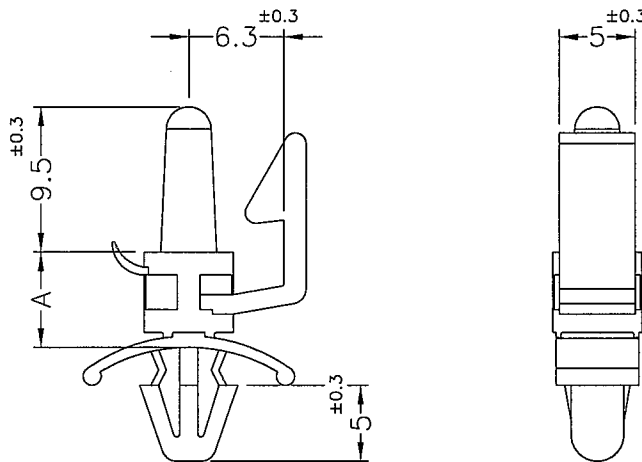
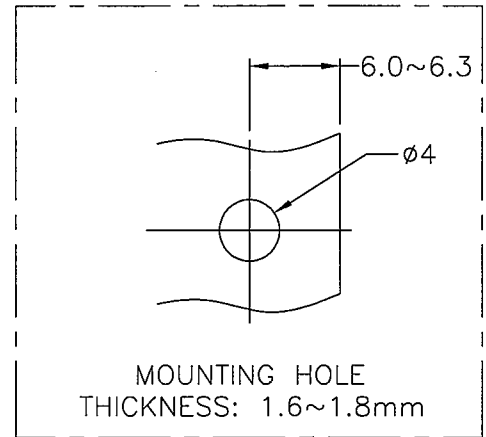

MOUNTING HOLE: $\phi 4.8\text{mm}$
THICKNESS: 0.5~2.0mm

PART NO.	A
ULCB-6	6.3
ULCB-8	8.0

NOTE: 1. SHRINKING IS NORMAL STATUS.

內縮為正常現象。

2. MADE OF EQUIVALENT MATERIAL.

均可使用同等材質。

3. THE COLOR BATCH TEST REPORT IS ONLY FOR FIRST LOT TEST.

色母環保檢測報告, 僅提供原始測試報告。



康揚企業股份有限公司

KANG YANG HARDWARE ENTERPRISE CO., LTD.

康揚塑膠(東莞)有限公司

KANG YANG PLASTIC(DONG GUAN)CO.,LTD.

康哲電腦配件(吳江)有限公司

KANG CHE COMPUTER COMPONENTS(WUJIANG)CO.,LTD.

ISO 9001
ISO 14001
QC 080000
IATF 16949

PROPRIETARY AND CONFIDENTIAL THE INFORMATION CONTAINED IN THIS DRAWING IS THE SOLE PROPERTY OF KANG YANG HARDWARE ENTERPRISE CO. ANY REPRODUCTION IN PART OR AS A WHOLE WITHOUT THE WRITTEN PERMISSION OF KANG YANG HARDWARE ENTERPRISE CO. IS PROHIBITED.	DATE	2000.12.28	TITLE	SPACER SUPPORT	DWG. NO.	ULCB-H	PART NO.	SEE ABOVE
	DRAWN	JASON	MATERIAL	NYLON 66 UL94V-2	SIZE	A4	SPEC. DWG.	REV
	CHECKED		COLOR	NATURAL	FINISH			A
	APPROVED		UNLESS OTHERWISE SPECIFIED TOLERANCE: SEE ABOVE		SCALE:	2:1	UNIT	mm

DO NOT SCALE DRAWING