

Patented Product
專利產品

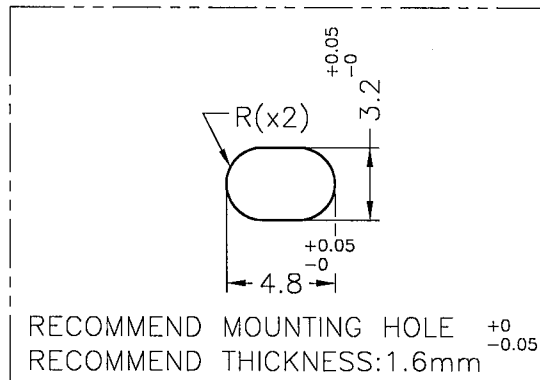
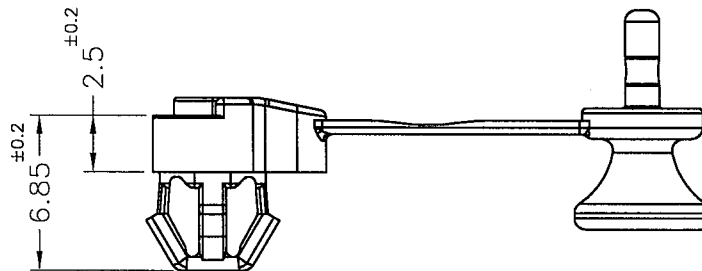
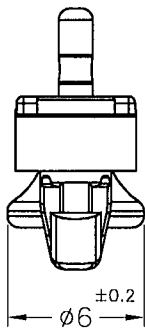
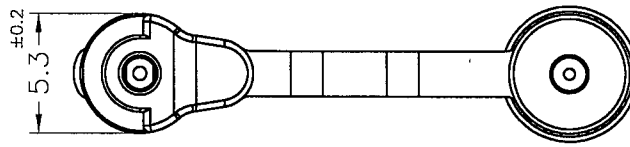

NOTE: 1. MADE OF EQUIVALENT MATERIAL.

均可使用同等材質。

2. SLIGHT DEFORMED IS NORMAL STATUS.

輕微變形為正常現象。

3. THE COLOR BATCH TEST REPORT IS ONLY FOR FIRST LOT TEST.

色母環保檢測報告，僅提供原始測試報告。

PART NO.	COLOR
ULCO2.5-1.6(GR)	GREEN
ULCO2.5-1.6(B)	BLACK
ULCO2.5-1.6(BU)	BLUE



康揚企業股份有限公司
KANG YANG HARDWARE ENTERPRISE CO., LTD.

康揚塑膠(東莞)有限公司
KANG YANG PLASTIC(DONG GUAN)CO., LTD.

康哲電腦配件(吳江)有限公司
KANG CHE COMPUTER COMPONENTS(WUJIANG)CO., LTD.

康揚塑膠五金(泰國)有限公司

บริษัท เคียงฮาร์ดแวร์ (ประเทศไทย) จำกัด
KANG YANG HARDWARE (THAILAND) CO., LTD.

康揚越南有限公司

CÔNG TY TNHH KANG YANG VIỆT NAM
KANG YANG HARDWARE (THAILAND) CO., LTD.

PROPRIETARY AND CONFIDENTIAL THE INFORMATION CONTAINED IN THIS DRAWING IS THE SOLE PROPERTY OF KANG YANG HARDWARE ENTERPRISE CO. ANY REPRODUCTION IN PART OR AS A WHOLE WITHOUT THE WRITTEN PERMISSION OF KANG YANG HARDWARE ENTERPRISE CO. IS PROHIBITED. DO NOT SCALE DRAWING	DATE	2013.12.27	TITLE	SPACER SUPPORT		DWG. NO.	ULCO2.5-1.6		PART NO.	SEE ABOVE	
	DRAWN	<i>H.W</i>	MATERIAL	NYLON66 UL94V-2		SIZE	A4		SPEC. DWG	REV	
	CHECKED	<i>Kenny</i>	COLOR	SEE ABOVE		FINISH				C	
	APPROVED	<i>Kang</i>	UNLESS OTHERWISE SPECIFIED TOLERANCE:	SEE ABOVE		SCALE:	3:1	UNIT	mm	SHEET 1 OF 1	