

Patented Product

專利產品

REVISIONS

REV	DESCRIPTION	DATE	BY

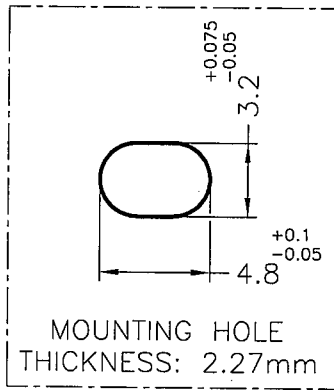
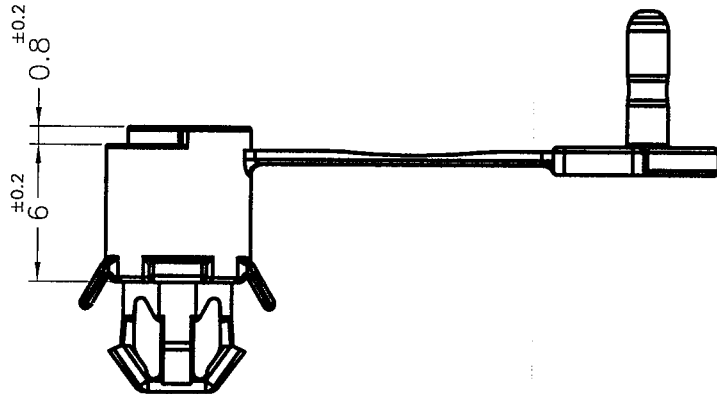
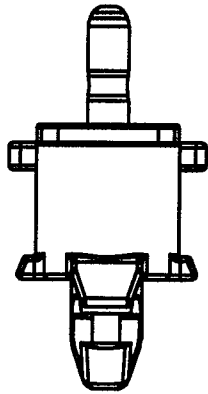
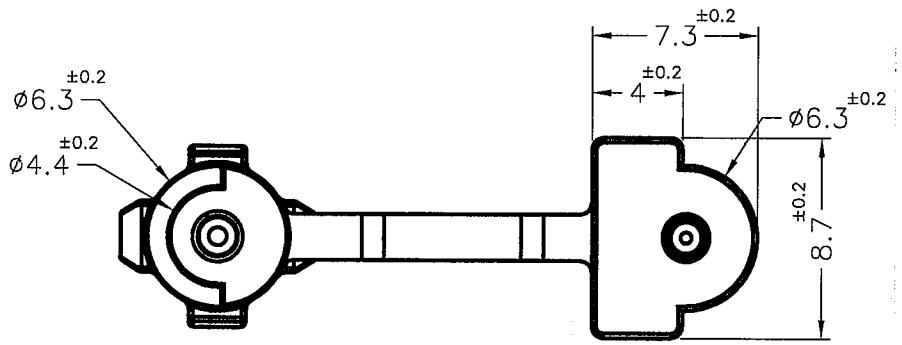

NOTE: 1. MADE OF EQUIVALENT MATERIAL.
 均可使用同等材質
 2. SHRINKING IS NORMAL STATUS.
 內縮為正常現象

 康揚企業股份有限公司 KANG YANG HARDWARE ENTERPRISE CO., LTD. 康揚塑膠(東莞)有限公司 KANG YANG PLASTIC(DONG GUAN) CO., LTD. 康哲電腦配件(吳江)有限公司 KANG CHE COMPUTER COMPONENTS(WUJIANG) CO., LTD.	TITLE		SPEC. DWG.		
	SPACER SUPPORT		DATE		
PART NUMBER		MATERIAL		DRAWN	
ULCOB-2(BU)		NYLON 66 UL94V-2		K.W	
DRAWING NUMBER		COLOR		CHECK	
ULCOB-2		BLUE(PANTONE 2718C)		彭永承	
SIZE	SCALE	UNIT	REV	APPROVED	
A4	3:1	mm	A	Kang	
UNLESS OTHERWISE SPECIFIED TOLERANCE				SEE ABOVE	