

Patented Product
專利產品

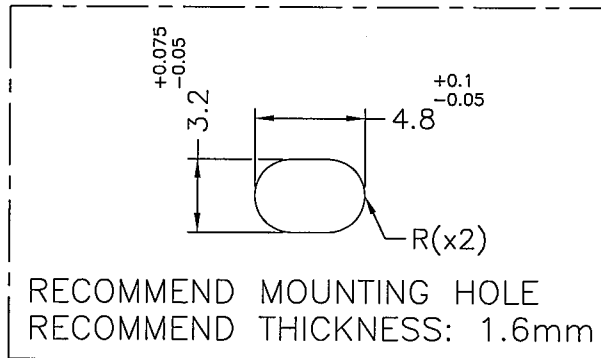
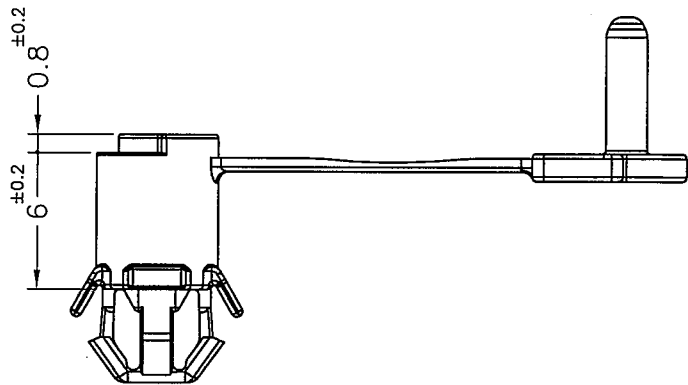
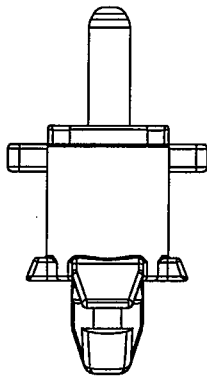
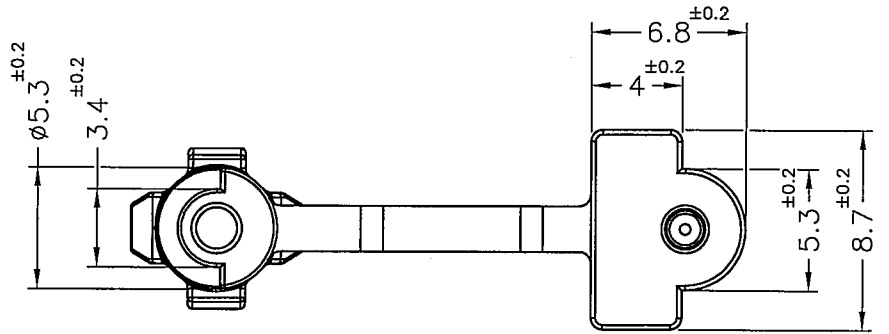

PART NO.	COLOR
ULCOB6-1.6(BU)	BLUE(PANTONE 2718C)
ULCOB6-1.6(B)	BLACK

NOTE: 1. MADE OF EQUIVALENT MATERIAL.

均可使用同等材質。

2. SLIGHT DEFORMED IS NORMAL STATUS.

輕微變形為正常現象。

3. THE COLOR BATCH TEST REPORT IS ONLY FOR FIRST LOT TEST.

色母環保檢測報告，僅提供原始測試報告。



康揚企業股份有限公司
KANG YANG HARDWARE ENTERPRISE CO., LTD.
康揚塑膠(東莞)有限公司
KANG YANG PLASTIC(DONG GUAN)CO., LTD.
康哲電腦配件(吳江)有限公司
KANG CHE COMPUTER COMPONENTS(WUJIANG)CO., LTD.

PROPRIETARY AND CONFIDENTIAL THE INFORMATION CONTAINED IN THIS DRAWING IS THE SOLE PROPERTY OF KANG YANG HARDWARE ENTERPRISE CO. ANY REPRODUCTION IN PART OR AS A WHOLE WITHOUT THE WRITTEN PERMISSION OF KANG YANG HARDWARE ENTERPRISE CO. IS PROHIBITED. DO NOT SCALE DRAWING	DATE	2022.11.07	TITLE	SPACER SUPPORT	DWG. NO.	PART NO.	
	DRAWN	K.W	MATERIAL	NYLON66 UL94V-2	ULCOB6-1.6		SEE ABOVE
	CHECKED		COLOR	SEE ABOVE	SIZE	SPEC. DWG	REV
	APPROVED		UNLESS OTHERWISE SPECIFIED TOLERANCE:	SEE ABOVE	A4		A
			SCALE: 3:1	UNIT	mm	SHEET 1 OF 1	