

Patented Product
專利產品

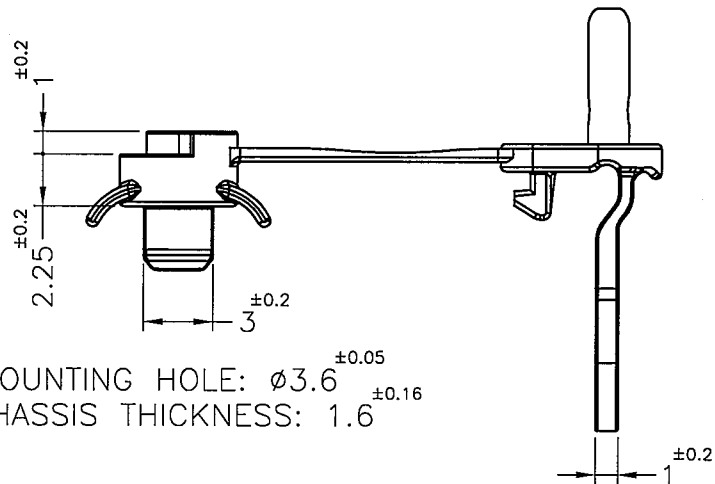

- NOTE: 1. SHRINKING IS NORMAL STATUS.
內縮為正常現象。
2. MADE OF EQUIVALENT MATERIAL.
可使用同等材質。
3. THE COLOR BATCH TEST REPORT IS ONLY FOR FIRST LOT TEST.
色母環保檢測報告, 僅提供原始測試報告。
4. SUGGESTED PULL OUT VALUE TO 0.8±0.2Kgf
建議PIN拉拔力0.8±0.2Kgf

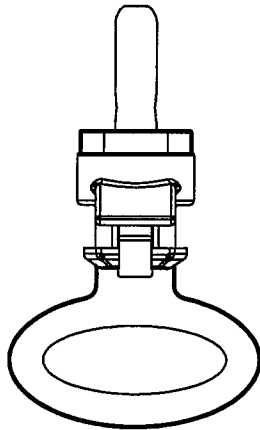
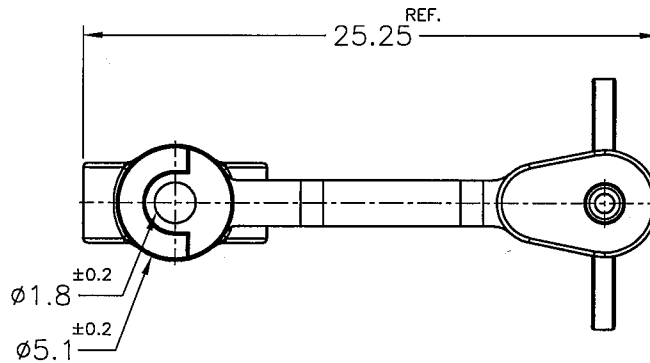
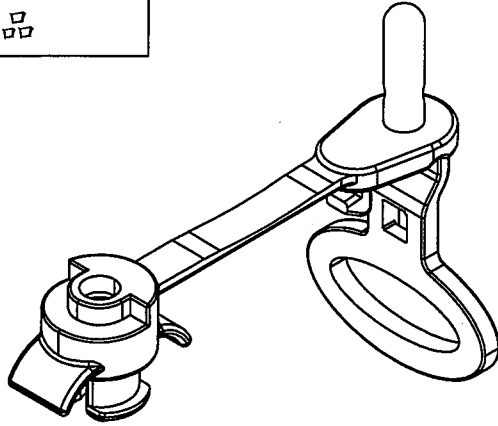

康揚企業股份有限公司
KANG YANG HARDWARE ENTERPRISE CO., LTD.
康揚塑膠(東莞)有限公司
KANG YANG PLASTIC(DONG GUAN)CO.,LTD.
康哲電腦配件(吳江)有限公司
KANG CHE COMPUTER COMPONENTS(WUJIANG)CO.,LTD.

PROPRIETARY AND CONFIDENTIAL THE INFORMATION CONTAINED IN THIS DRAWING IS THE SOLE PROPERTY OF KANG YANG HARDWARE ENTERPRISE CO. ANY REPRODUCTION IN PART OR AS A WHOLE WITHOUT THE WRITTEN PERMISSION OF KANG YANG HARDWARE ENTERPRISE CO. IS PROHIBITED. DO NOT SCALE DRAWING	DATE	2019.03.06	TITLE	SPACER SUPPORT	DWG. NO.	ULCOC-8	PART NO.	ULCOC-8(BU)
	DRAWN	K.W	MATERIAL	NYLON66 UL94V-2	SIZE	A4	SPEC. DWG	REV
	CHECKED		COLOR	BLUE(PANTONE 285C)				A
	APPROVED	<i>Kang</i>	UNLESS OTHERWISE SPECIFIED TOLERANCE:	SEE ABOVE	SCALE:	3:1	UNIT	mm