

Patented Product
專利產品

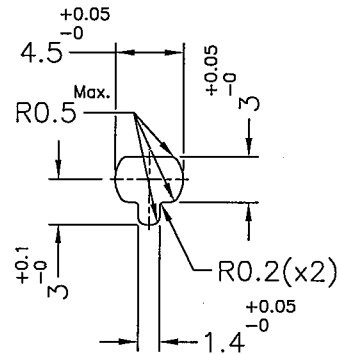

RECOMMEND MOUNTING HOLE $\begin{matrix} +0 \\ -0.05 \end{matrix}$
RECOMMEND THICKNESS: 1.6mm

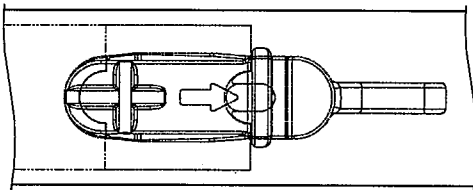
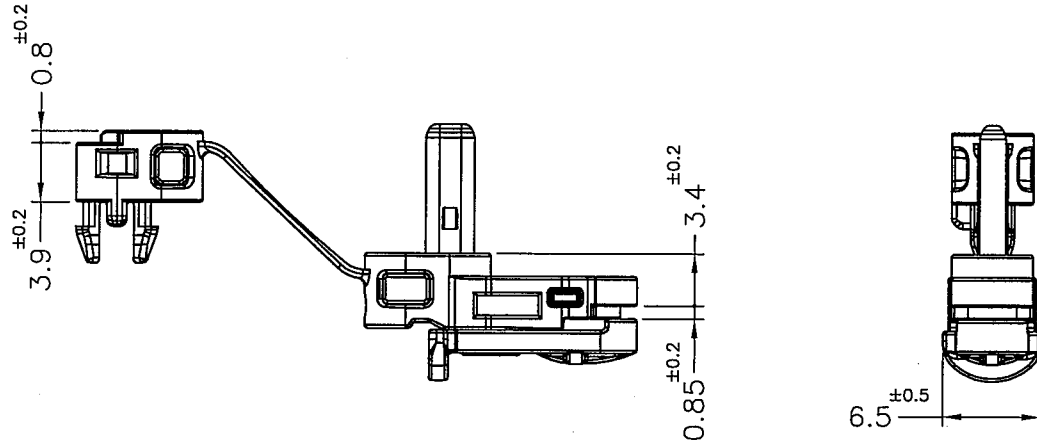
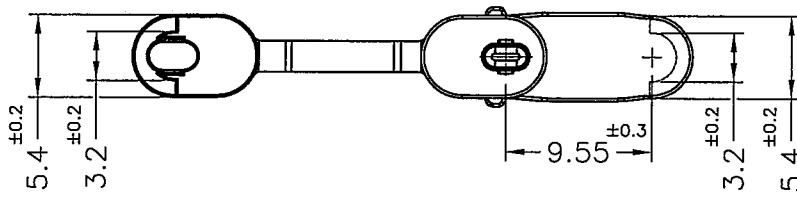
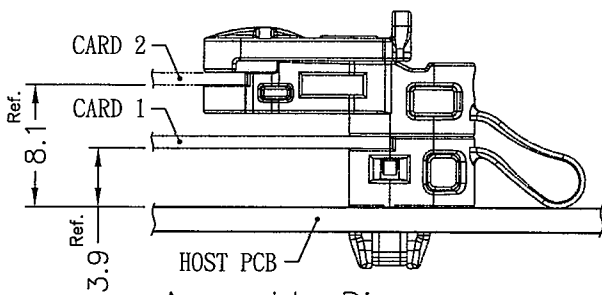

Assembly Diagram

PART NO.	ULCOF-19V0F		
COMPONENT NAME	MATERIAL	COLOR	FINISH
LATCH - BASE	NYLON 66 UL94V-0	BLACK	
LATCH - HANDLE	NYLON 66 UL94V-0+GF	BLUE	
LATCH - SPRING	SWP		NICKLE PLATED

NOTE: 1. MADE OF EQUIVALENT MATERIAL.

均可使用同等材質。

2. SLIGHT DEFORMED IS NORMAL STATUS.

輕微變形為正常現象。

3. THE COLOR BATCH TEST REPORT IS ONLY FOR FIRST LOT TEST.

色母環保檢測報告，僅提供原始測試報告。



康揚企業股份有限公司
KANG YANG HARDWARE ENTERPRISE CO., LTD.
康揚塑膠(東莞)有限公司
KANG YANG PLASTIC(DONG GUAN)CO.,LTD.
康哲電腦配件(吳江)有限公司
KANG CHE COMPUTER COMPONENTS(WUJIANG)CO.,LTD.

PROPRIETARY AND CONFIDENTIAL
THE INFORMATION CONTAINED IN THIS DRAWING IS THE SOLE PROPERTY OF KANG YANG HARDWARE ENTERPRISE CO. ANY REPRODUCTION IN PART OR AS A WHOLE WITHOUT THE WRITTEN PERMISSION OF KANG YANG HARDWARE ENTERPRISE CO. IS PROHIBITED.

DATE 2022.07.21
DRAWN K.W.
CHECKED
APPROVED

TITLE LATCH SPACER SUPPORT
MATERIAL SEE ABOVE
COLOR SEE ABOVE FINISH SEE ABOVE
UNLESS OTHERWISE SPECIFIED TOLERANCE: SEE ABOVE

DWG. NO. ULCOF-19V0F
SIZE A4
SCALE: 2:1

PART NO. ULCOF-19V0F
SPEC. DWG
REV A
UNIT mm
SHEET 1 OF 1

DO NOT SCALE DRAWING