

PART NO.	COLOR
ULCSE-7V0(BU)	BLUE(PANTONE 291C)
ULCSE-7V0(BU1)	BLUE(PANTONE 279C)

NOTE:1. SHRINKING IS NORMAL STATUS.

內縮為正常現象。

2. MADE OF EQUIVALENT MATERIAL.

均可使用同等材質。

3. THE COLOR BATCH TEST REPORT IS ONLY FOR FIRST LOT TEST.

色母環保檢測報告, 僅提供原始測試報告。

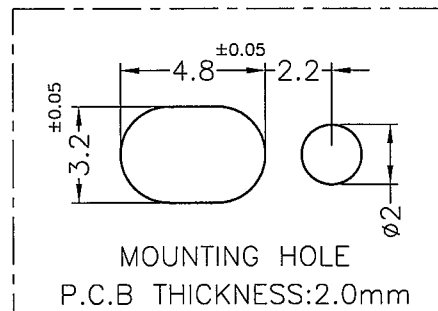

康揚企業股份有限公司
KANG YANG HARDWARE ENTERPRISE CO., LTD.
康揚塑膠(東莞)有限公司
KANG YANG PLASTIC(DONG GUAN)CO.,LTD.
康哲電腦配件(吳江)有限公司
KANG CHE COMPUTER COMPONENTS(WUJIANG)CO.,LTD.

PROPRIETARY AND CONFIDENTIAL THE INFORMATION CONTAINED IN THIS DRAWING IS THE SOLE PROPERTY OF KANG YANG HARDWARE ENTERPRISE CO. ANY REPRODUCTION IN PART OR AS A WHOLE WITHOUT THE WRITTEN PERMISSION OF KANG YANG HARDWARE ENTERPRISE CO. IS PROHIBITED. DO NOT SCALE DRAWING	DATE	2019.01.03	TITLE	SPACER SUPPORT	DWG. NO.	ULCSE-7		PART NO.	SEE ABOVE
	DRAWN	FORSEN	MATERIAL	NYLON 66 UL94V-0	SIZE	A4		SPEC. DWG	REV
	CHECKED	林祺翔	COLOR	SEE ABOVE	FINISH				B
	APPROVED	Kang	UNLESS OTHERWISE SPECIFIED TOLERANCE:	SEE ABOVE	SCALE:	4:1	UNIT	mm	SHEET 1 OF 1