

WITH HALOGEN
有鹵料件

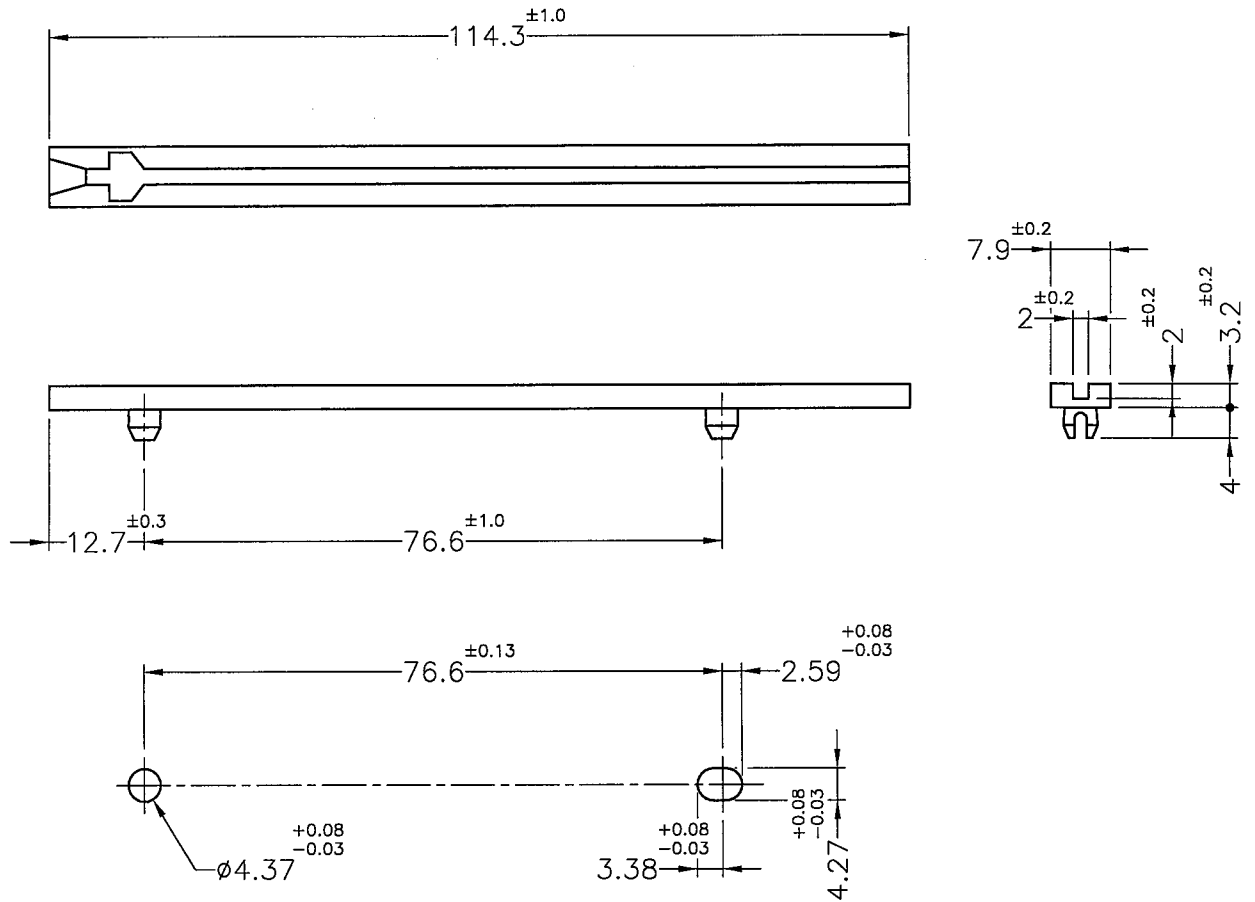

RECOMMEND MOUNTING HOLE

NOTE: 1. SHRINKING IS NORMAL STATUS.

內縮為正常現象。

2. MADE OF EQUIVALENT MATERIAL.

可使用同等材質。

3. THE COLOR BATCH TEST REPORT IS ONLY FOR FIRST LOT TEST.

色母環保檢測報告, 僅提供原始測試報告。



康揚企業股份有限公司
KANG YANG HARDWARE ENTERPRISE CO., LTD.
康揚塑膠(東莞)有限公司
KANG YANG PLASTIC(DONG GUAN)CO., LTD.
康哲電腦配件(吳江)有限公司
KANG CHE COMPUTER COMPONENTS(WUJIANG)CO., LTD.

PROPRIETARY AND CONFIDENTIAL THE INFORMATION CONTAINED IN THIS DRAWING IS THE SOLE PROPERTY OF KANG YANG HARDWARE ENTERPRISE CO. ANY REPRODUCTION IN PART OR AS A WHOLE WITHOUT THE WRITTEN PERMISSION OF KANG YANG HARDWARE ENTERPRISE CO. IS PROHIBITED. DO NOT SCALE DRAWING	DATE	2023.11.17	TITLE	CARD GUIDE	DWG. NO.	CGG-114V1B	PART NO.	CGG-114V1B
	DRAWN	FORSEN	MATERIAL	NYLON 66 UL94V-0+GF	SIZE	A4	SPEC. DWG.	REV
	CHECKED	Yuping	COLOR	BLACK	FINISH			A
	APPROVED	Kang	UNLESS OTHERWISE SPECIFIED	TOLERANCE: SEE ABOVE	SCALE: 1:1	UNIT	mm	SHEET 1 OF 1

C