

Patented Under Process
專利申請中

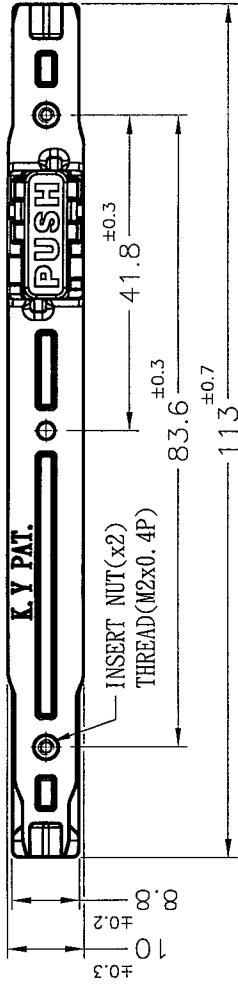

19.05 Ref. (CLOSE)
22.3 Ref. (OPEN)

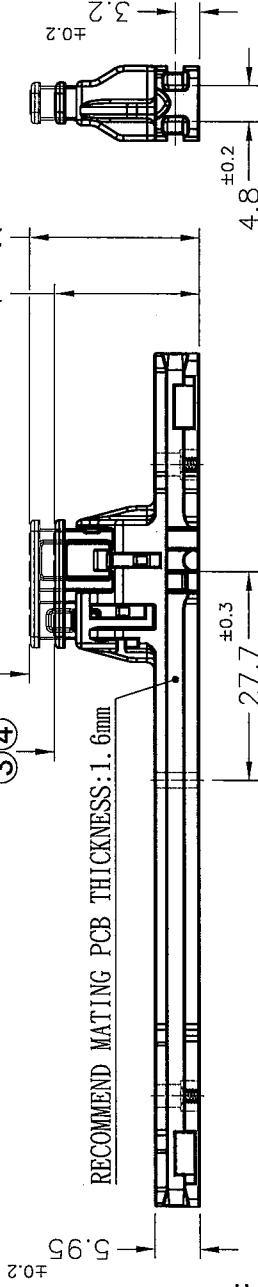

Note:

1. Finished dimensions Location.

- 成品尺寸位置。
- ① Minimum press-in distance to lock: 4.3 Ref.
扣合所需的最小距離位置
 - ② Maximum press-in distance to lock: 4.5 Ref.
扣合時最大壓入位置
 - ③ Minimum press-in distance to unlock: 1.1 Ref.
打開所需的最小距離位置
 - ④ Maximum press-in distance to unlock: 1.3 Ref.
打開時最大壓入位置

2. Made of equivalent material.

均可使用同等材質。

3. Slight deformed is normal status.

輕微變形為正常現象。

4. The color batch test report is only for first lot test.

色母環保檢測報告, 僅提供原始測試報告。

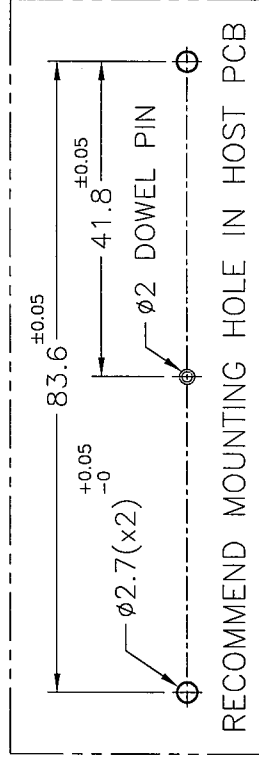
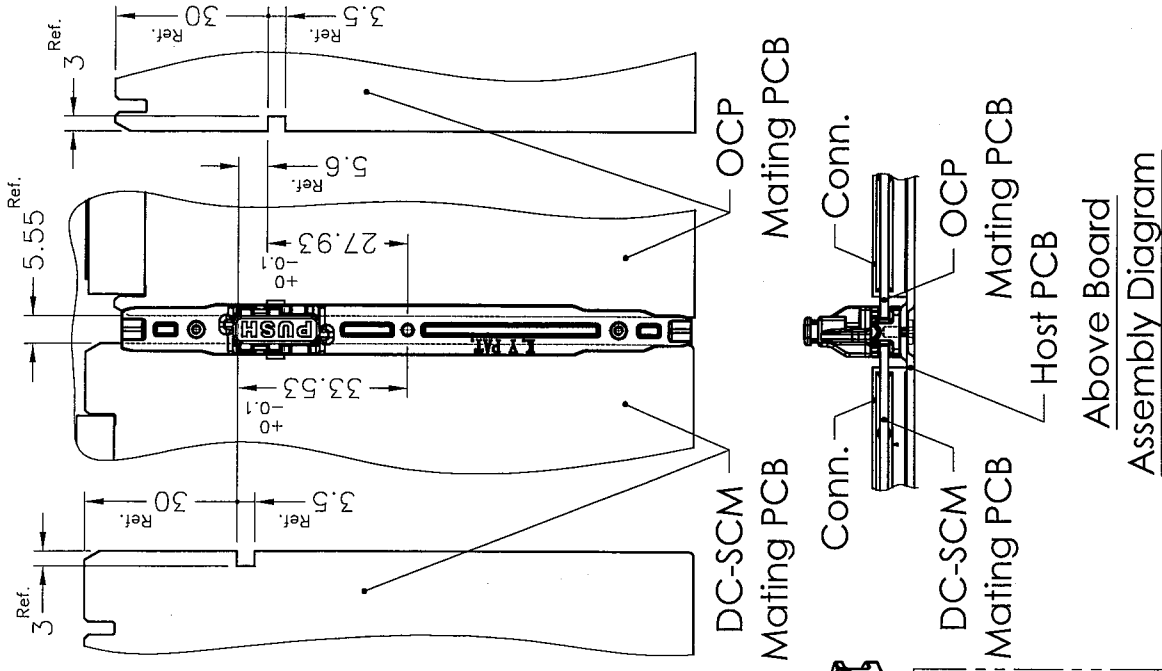

 9001 ISO 14001 CCC 080200 IATF 16949	康揚企業股份有限公司 KANG YANG HARDWARE ENTERPRISE CO., LTD. 康揚塑膠(東莞)有限公司 KANG YANG PLASTIC(DONG GUAN)CO.,LTD. 康哲電腦配件(吳江)有限公司 KANG CHE COMPUTER COMPONENTS(WUJIANG)CO.,LTD.	DATE 2025.04.16 DRAWN <i>M.D.W</i> CHECKED <i>Kenny</i> APPROVED <i>Kenny</i>	TITLE CARD GUIDE MATERIAL PC+ABS UL94V-0 COLOR SEE ABOVE INSERT NUT MATERIAL BRASS UNLESS OTHERWISE SPECIFIED TOLERANCE SEE ABOVE	DWG. NO. CGLP-13F PART NO. CGLP-13VGF-M2	SIZE A4 SPEC. DWG REV A	SCALE: 1:1 UNIT mm SHEET 1 OF 1
	PROPRIETARY AND CONFIDENTIAL: THE INFORMATION CONTAINED IN THIS DRAWING IS THE SOLE PROPERTY OF KANG YANG HARDWARE ENTERPRISE CO. ANY REPRODUCTION IN PART OR AS A WHOLE WITHOUT THE WRITTEN PERMISSION OF KANG YANG HARDWARE ENTERPRISE IS PROHIBITED. (DO NOT SCALE DRAWING)					