

8



- 塑膠螺絲
Plastic Screws
- 螺絲帽蓋
Screw Caps & Bonnets
- 塑膠螺帽
Plastic Nuts
- 止付螺絲
Set Screws
- 手轉螺絲
Thumb Screws
- 螺絲墊片
Screw Washer
- 墊片/華司
Washer



螺絲帽蓋 SCREW CAP

用途：用於螺絲凸出之保護，美觀不刮手，避免不當之拆卸。



- Material: Nylon 66 (UL)
- Flame Class: 94V-2/94V-0
- Color: Natural/Black
- Unit: mm

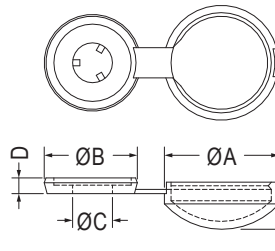

Part No.	A	B	C	D	Package
SCW-1	9.8	8.0	3.3	1.3	1000
SCW-2	13.3	11.6	4.3	1.4	

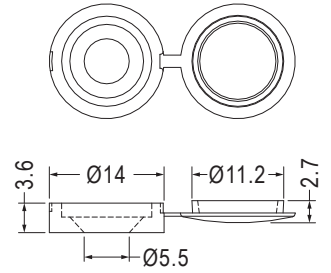

Part No.	Package
SCW-3	1000

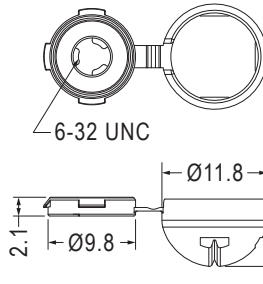
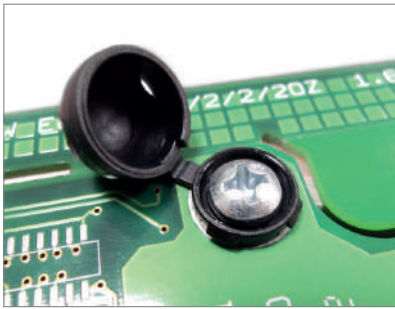

Part No.	Package
SCW-5	1000

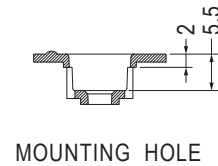
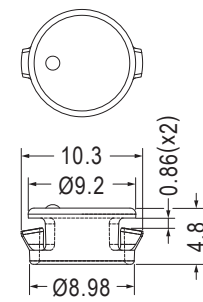

Part No.	Package
SCWA-6	1000

螺絲帽蓋 SCREW BONNET

用途：配合一般螺絲，作為螺絲蓋使用。



- Material: Nylon 66 (UL)
- Flame Class: 94V-2/94V-0
- Color: Natural/Black
- Unit: mm

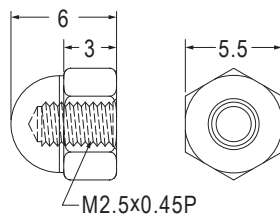

Part No.	Package
MP-2.5	1000

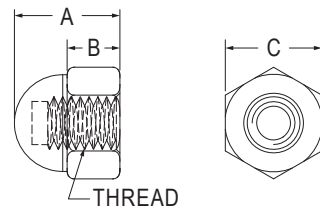

Part No.	A	B	C	Thread	Package
MP-3	6.0	3.0	5.5	M3x0.5P	1000
MP-4	8.0	4.0	7.7	M4x0.7P	
MP-6	11.9	8.5	10.0	M6x1.0P	

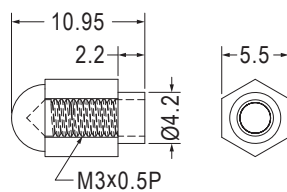

Part No.	Package
MP-5	1000

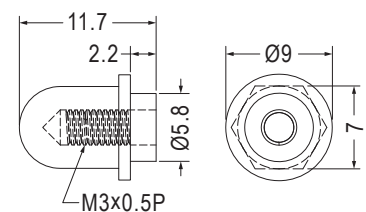

Part No.	Package
MP-26	1000

螺絲帽蓋 SCREW BONNET

用途：配合一般螺絲，作為螺絲蓋使用。



- Material: Nylon 66 (UL)
- Flame Class: 94V-2/94V-0
- Color: Natural/Black
- Unit: mm

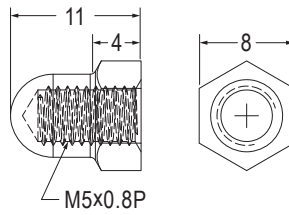

Part No.	Package
MP5-1	1000

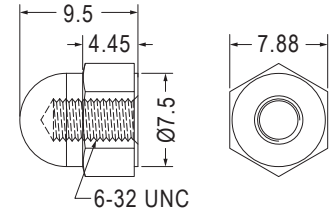

Part No.	Package
MP-632	1000

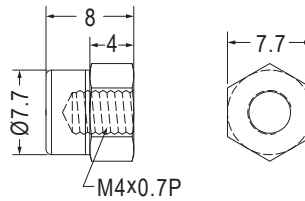

Part No.	Package
MP-4-1	1000

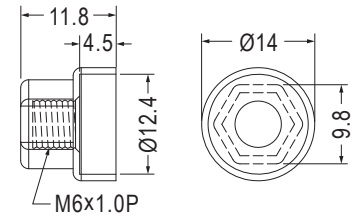

- Material: PBT
- Color: Black

Part No.	Package
MP6-1	1000

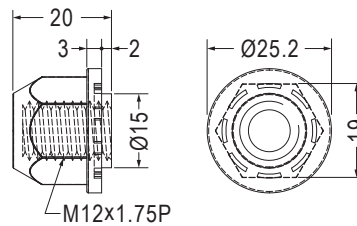

Part No.	Package
MP-12	250

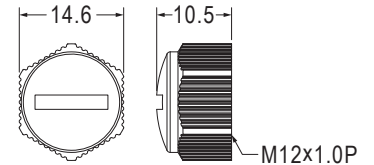

- Material: PC+ABS (UL)
- Flame Class: 94V-0
- Color: Black

Part No.	Package
★ MP12-1	500

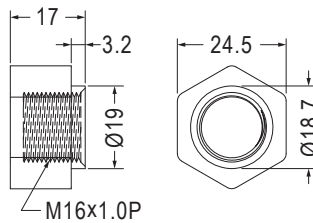

- Material: POM
- Color: Natural

Part No.	Package
MP16-1	250

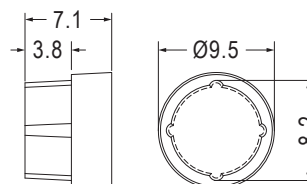

Part No.	Package
SWVB-1	1000

螺絲帽蓋 SCREW BONNET

用途：配合一般螺絲，作為螺絲蓋使用。



- Material: Nylon 66 (UL)
- Flame Class: 94V-2/94V-0
- Color: Natural/Black
- Unit: mm

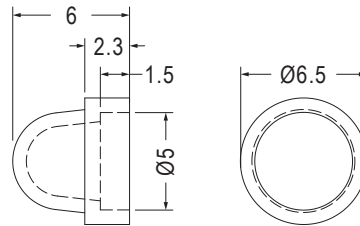

Part No.	Package
SWV-4	1000



- Material: Silicon Rubber
- Color: Black
- Unit: mm

用途：配合M8螺絲，作為螺絲蓋使用。

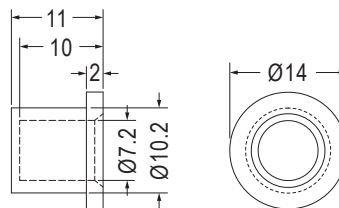

Part No.	Package
TF-250	1000

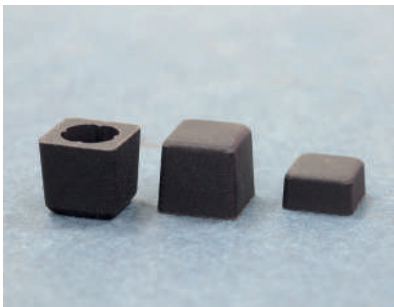

- Material: Silicon Rubber
- Color: Black
- Unit: mm

用途：配合一般螺絲，作為螺絲蓋使用。

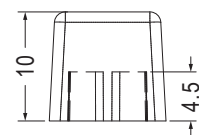
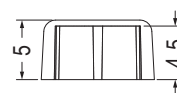
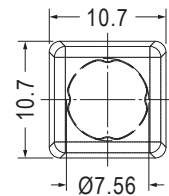
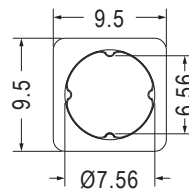

Part No.	Package
EMC-40	1000

Part No.	Package
EMC-41	1000

塑膠螺帽 NUT

用途：配合一般螺絲或塑膠螺絲使用。



- Material: Nylon 66 (UL)
- Flame Class: 94V-2/94V-0
- Color: Natural/Black
- Unit: mm

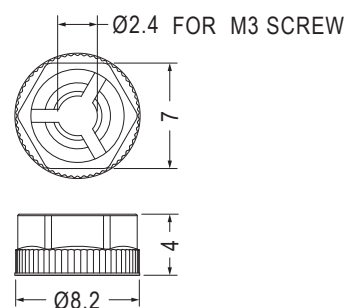

Part No.	Package
MOA3	1000

塑膠螺帽 NUT

用途：配合一般螺絲或塑膠螺絲使用。



- Material: Nylon 66 (UL)
- Flame Class: 94V-2/94V-0
- Color: Natural/Black
- Unit: mm

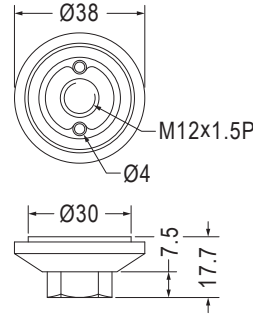

Part No.	Package
CAM-12	100

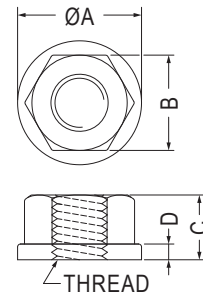
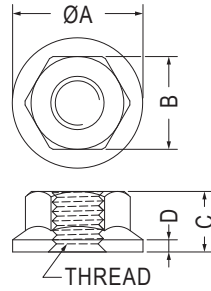

Part No.	A	B	C	D	Thread	Package
MO-3	8.5	5.4	3.2	0.8	M3x0.5P	1000
MO-3-3.7	8.5	5.4	3.7	0.8	M3x0.5P	
MO-4	9.7	6.9	4.5	0.9	M4x0.7P	
MO-632	10.6	7.8	4.2	1.0	6-32 UNC	

Part No.	A	B	C	D	Thread	Package
MO-6G-68	13.0	10.0	6.8	1.65	M6x1.0P	2000
MO-8G-85	17.0	13.0	8.5	1.9	M8x1.25P	1000

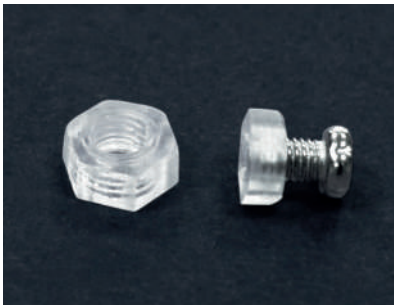

- Material: Nylon 66 (UL)/PC (UL)
- Flame Class: 94V-2/94V-0
- Color: Natural
- Unit: mm

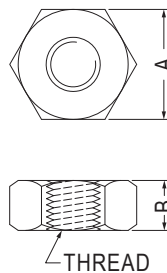

Part No.	A	B	Thread	Package
M-2	3.95	1.4	M2x0.4P	2000
M-2L	3.95	3.0	M2x0.4P	
M-2.5	5.0	2.0	M2.5x0.45P	
M-2.6	5.0	2.0	M2.6x0.45P	
M-3	5.5	2.7	M3x0.5P	
M-3S	5.4	2.4	M3x0.5P	1000
M-3.5	5.9	2.8	M3.5x0.6P	
M-4	6.9	3.3	M4x0.7P	
M-4F	7.0	2.5	M4x0.7P	
M-5	8.0	4.4	M5x0.8P	
M-6	10.0	5.0	M6x1.0P	
S4-40	6.4	2.5	4-40 UNC	
S6-32	7.9	3.2	6-32 UNC	



- Material: Nylon 66 (UL)
- Flame Class: 94V-2/94V-0
- Color: Natural/Black
- Unit: mm

用途：配合鏡頭調整或塑膠螺絲使用。

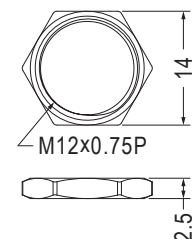
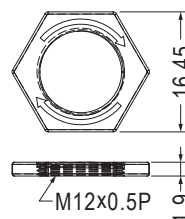

Part No.	Package
M12-2	2000

Part No.	Package
MOC-12	1000

塑膠螺帽 NUT

用途：配合一般螺絲或塑膠螺絲使用。



- Material: Nylon 66 (UL)
- Flame Class: 94V-2/94V-0
- Color: Natural/Black
- Unit: mm

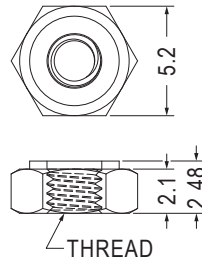

Part No.	Thread	Package
MOB-2.5	M2.5x0.45P	1000
MOB-2.6	M2.6x0.45P	

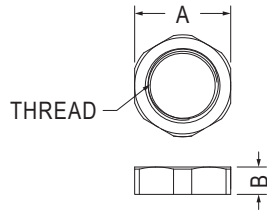

Part No.	A	B	Thread	Package
MOPG-7	17.1	5.0	PG7	1000
MOPG-9	22.0	5.1	PG9	
MOPG-11	24.0	6.1	PG11	
MOPG-13.5	27.2	6.1	PG13.5	

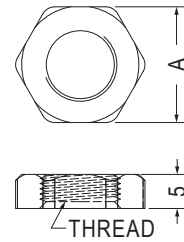

Part No.	A	Thread	Package
M-10	17.0	M10x1.5P	500
MO-12	17.9	M12x1.5P	1000



- Material: Nylon 66 (UL)/PP
- Flame Class: 94V-2/94V-0
- Color: Natural/Black
- Unit: mm

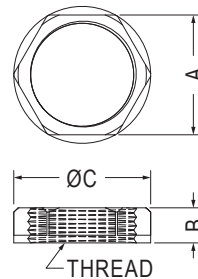

Part No.	A	B	C	Thread	Package
MO-8-1	12.0	5.0	13.0	M8x1.0P	1000
MO-13	14.0	4.1	16.0	M13x1.0P	
MO-16	22.0	6.6	24.7	M16x1.5P	
MO-20	27.0	6.6	29.8	M20x1.5P	
MO-25	33.0	8.5	36.2	M25x1.5P	500
MO-25-1	33.0	6.6	35.4	M25x1.5P	
MO-25.4	38.2	11.7	42.2	PF1-11	100
MO-32L	36.6	8.2	41.15	M32x1.5P	500
MO-32	41.0	7.6	46.4	M32x1.5P	
★MO-40L	50.0	10.0	54.8	M40x1.5P	



- Material: Nylon 6 (UL)
- Flame Class: 94HB
- Color: Black
- Unit: mm

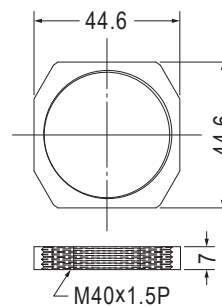

Part No.	Package
MO-40	250

翼型螺帽 WING NUT

用途：配合一般螺絲或塑膠螺絲使用。



- Material: Nylon 66 (UL)
- Flame Class: 94V-2/94V-0
- Color: Natural/Black
- Unit: mm

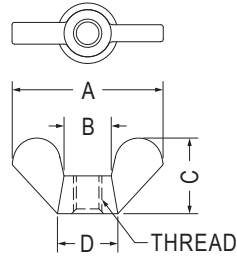

Part No.	A	B	C	D	Thread	Package
SMO-3	15.96	5.0	8.0	6.4	M3x0.5P	1000
SMO-4	21.5	8.0	10.1	10.0	M4x0.7P	
SMO-632	22.0	8.0	10.5	10.0	6-32 UNC	
SMO-832	21.0	8.0	10.0	10.0	8-32 UNC	

翼型螺絲 WING BOLT

用途：用於固定需絕緣之零件，重量輕，耐腐蝕。



- Material: Nylon 66 (UL)
- Flame Class: 94V-2/94V-0
- Color: Natural/Black
- Unit: mm

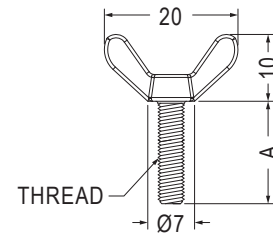
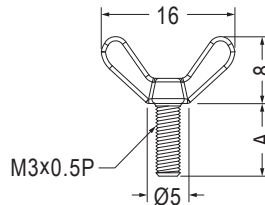

Part No.	A	Package
SM3-6	6.0	1000
SM3-8	8.0	
SM3-10	10.0	
SM3-12	12.0	

Part No.	A	Thread	Package
SM4-6	6.0	M4x0.7P	1000
SM4-8	8.0	M4x0.7P	
SM4-10	10.0	M4x0.7P	
SM4-12	12.0	M4x0.7P	
SM632-6	6.35	6-32 UNC	
SM632-8	8.0	6-32 UNC	
SM632-9	9.5	6-32 UNC	
SM632-12	12.7	6-32 UNC	

塑膠螺絲 SCREW

用途：用於固定需絕緣之零件，重量輕，耐腐蝕。

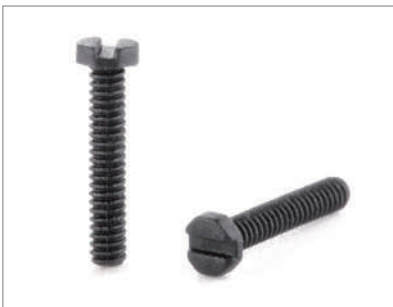

- Material: Nylon 66 (UL)+GF
- Flame Class: 94HB
- Color: Black
- Unit: mm

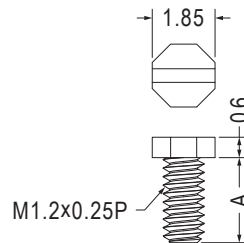

Part No.	A	Package
MI1.2-2.5NGF	2.5	1000
MI1.2-3NGF	3.0	
MI1.2-4NGF	4.0	
MI1.2-5NGF	5.0	
MI1.2-6NGF	6.0	

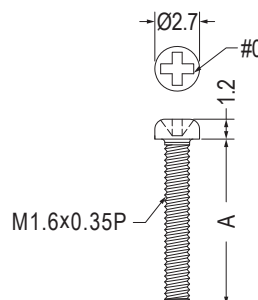

Part No.	A	Package
M1.6-3	3.0	1000
M1.6-4	4.0	
M1.6-4.5	4.5	
M1.6-5	5.0	
M1.6-6	6.0	
M1.6-7	7.0	
M1.6-8	8.0	
M1.6-9	9.0	
M1.6-10	10.0	

塑膠螺絲 SCREW

用途：用於固定需絕緣之零件，重量輕，耐腐蝕。



- Material: Nylon 66 (UL)
- Flame Class: 94V-2/94V-0
- Color: Natural/Black
- Unit: mm

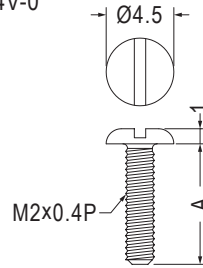

Part No.	A	Package
MI2-6	6.0	1000
MI2-8	8.0	
MI2-10	10.0	
MI2-12	12.0	

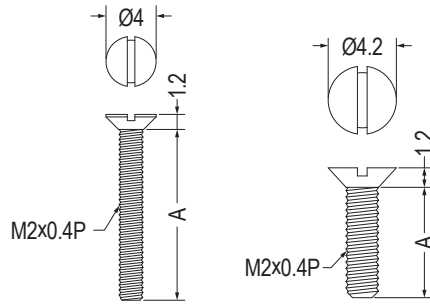

【 MI2-14.8F 】

Part No.	A	Package
MI2-3.8F	3.8	1000
MI2-4.8F	4.8	
MI2-5.8F	5.8	
MI2-6.8F	6.8	
MI2-7.8F	7.8	
MI2-8.8F	8.8	
MI2-9.8F	9.8	
MI2-14.8F	14.8	

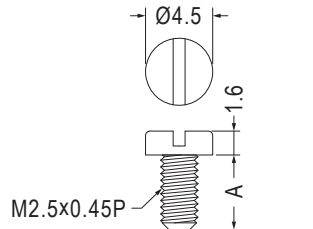

Part No.	A	Package
MI2.5-5	5.0	2000
MI2.5-12	12.0	

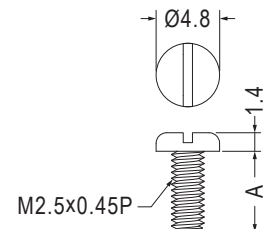

Part No.	A	Package
MI2.5-4	4.0	2000
MI2.5-12S	12.0	
MI2.5-16	16.0	

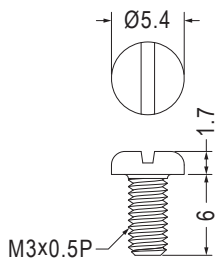

Part No.	Package
MI3-6R	1000

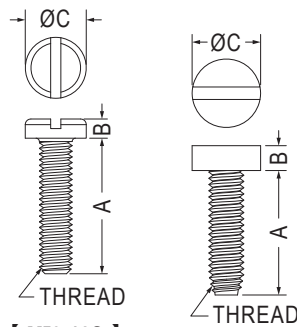

【 MI3-12S 】

Part No.	A	B	C	Thread	Package
MI3-3	3.0	2.0	5.5	M3x0.5P	1000
MI3-5	5.0	2.0	5.5	M3x0.5P	
MI3-6	6.0	2.0	5.5	M3x0.5P	
MI3-8	8.0	2.0	5.5	M3x0.5P	
MI3-10	10.0	2.0	5.5	M3x0.5P	
MI3-12	12.0	2.0	5.5	M3x0.5P	
MI3-12S	12.0	1.7	5.4	M3x0.5P	
★ MI4-6	6.0	2.4	8.0	M4x0.7P	
MI4-7	7.0	2.7	7.0	M4x0.7P	
MI4-10	10.0	2.7	7.0	M4x0.7P	



- Material: PEEK (UL)
- Flame Class: 94V-0
- Color: Natural
- Unit: mm

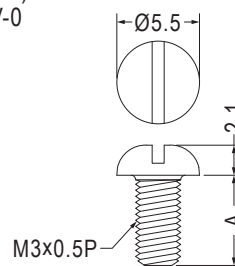

Part No.	A	Package
MI3-4PK	4.0	1000
MI3-5PK	5.0	
MI3-6PK	6.0	
MI3-8PK	8.0	

Part No.	A	Package
MI3-8PK	8.0	1000
MI3-10PK	10.0	
MI3-12PK	12.0	
MI3-14PK	14.0	
MI3-15PK	15.0	
MI3-17PK	17.0	
MI3-18PK	18.0	
MI3-20PK	20.0	
MI3-25PK	25.0	
MI3-30PK	30.0	

塑膠螺絲 SCREW

用途：用於固定需絕緣之零件，重量輕，耐腐蝕。



- Material: Nylon 66 (UL)/PC (UL)
- Flame Class: 94V-2/94V-0
- Color: Natural
- Unit: mm

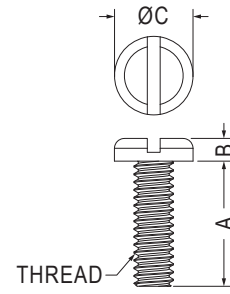
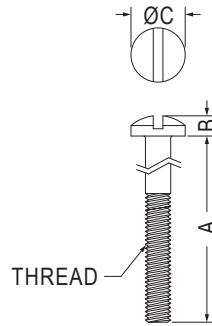
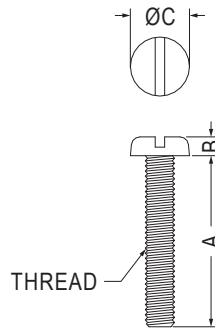

【 S632-25, S632-28 】

【 S632-4.8S~S632-50.8S, S832-6.3~S832-31.8 】

Part No.	A	B	C	Thread	Package
M3.5-10	10.0	2.2	6.9	M3.5x0.6P	1000
M3.5-15	15.0	2.2	6.9	M3.5x0.6P	
M3.5-20	20.0	2.2	6.9	M3.5x0.6P	
M3.5-25	25.0	2.2	6.9	M3.5x0.6P	
M3.5-30	30.0	2.2	6.9	M3.5x0.6P	
S440-6	6.4	2.1	5.2	4-40 UNC	2000
S440-8	8.0	2.1	5.2	4-40 UNC	
S440-9	9.5	2.1	5.2	4-40 UNC	
S440-12	12.7	2.1	5.2	4-40 UNC	1000
S440-15	15.5	2.1	5.2	4-40 UNC	
★ S632-4.8S	4.75	1.96	6.68	6-32 UNC	2000
★ S632-31.8S	31.75	1.96	6.68	6-32 UNC	1000
★ S632-50.8S	50.8	1.96	6.68	6-32 UNC	
S632-6	6.35	2.5	6.7	6-32 UNC	2000

Part No.	A	B	C	Thread	Package
S632-8	8.0	2.5	6.7	6-32 UNC	2000
S632-9	9.5	2.5	6.7	6-32 UNC	1000
S632-12	12.7	2.5	6.7	6-32 UNC	
S632-15	15.9	2.5	6.7	6-32 UNC	
S632-19	19.1	2.5	6.7	6-32 UNC	
S632-25	25.4	2.5	6.7	6-32 UNC	
S632-28	28.0	2.5	6.7	6-32 UNC	
★ S832-6.3	6.3	2.31	7.98	8-32 UNC	
★ S832-9.5	9.5	2.31	7.98	8-32 UNC	
★ S832-12.7	12.7	2.31	7.98	8-32 UNC	
★ S832-15.9	15.9	2.31	7.98	8-32 UNC	
★ S832-19.1	19.1	2.31	7.98	8-32 UNC	
★ S832-25.4	25.4	2.31	7.98	8-32 UNC	
★ S832-31.8	31.8	2.31	7.98	8-32 UNC	



- Material: PEEK (UL)
- Flame Class: 94V-0
- Color: Natural
- Unit: mm

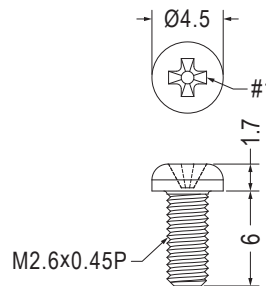

NEW

Part No.	Package
M2.6-6LPK	2000



- Material: PEEK (UL)
- Flame Class: 94V-0
- Color: Natural
- Unit: mm

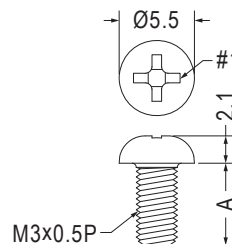

Part No.	A	Package
M3-4PK	4.0	2000
M3-5PK	5.0	
M3-6PK	6.0	

Part No.	A	Package
M3-8PK	8.0	1000
M3-10PK	10.0	
M3-12PK	12.0	
M3-14PK	14.0	
M3-15PK	15.0	
M3-17PK	17.0	
M3-18PK	18.0	
M3-20PK	20.0	
M3-25PK	25.0	
M3-30PK	30.0	

塑膠螺絲 SCREW

用途：用於固定需絕緣之零件，重量輕，耐腐蝕。



- Material: Nylon 66 (UL)/PC (UL)
- Flame Class: 94V-2/94V-0
- Color: Natural
- Unit: mm

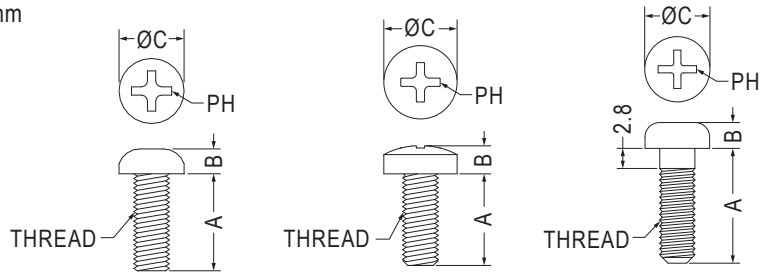

【 M4-8L, M4-10L 】

【 M5-10, M5-16, M5-20 】

Part No.	A	B	C	PH	Thread	Package
★ M2-2	2.0	1.4	3.3	#0	M2x0.4P	2000
★ M2-2L	2.0	1.4	4.0	#1	M2x0.4P	
M2-3	3.0	1.4	3.3	#0	M2x0.4P	
M2-4	4.0	1.4	3.3	#0	M2x0.4P	
M2-5	5.0	1.4	3.3	#0	M2x0.4P	
M2-6	6.0	1.4	3.3	#0	M2x0.4P	
M2-6.5	6.5	1.4	3.3	#0	M2x0.4P	
M2-8	8.0	1.4	3.3	#0	M2x0.4P	
M2-10	10.0	1.4	3.3	#0	M2x0.4P	
M2-12	12.0	1.4	3.3	#0	M2x0.4P	
M2-15	15.0	1.4	3.3	#0	M2x0.4P	
M2.5-4	4.0	1.5	4.3	#1	M2.5x0.45P	
M2.5-5	5.0	1.5	4.3	#1	M2.5x0.45P	
M2.5-6	6.0	1.5	4.3	#1	M2.5x0.45P	
M2.5-8	8.0	1.5	4.3	#1	M2.5x0.45P	
M2.5-10	10.0	1.5	4.3	#1	M2.5x0.45P	
M2.5L-13	13.0	1.5	6.3	#1	M2.5x0.45P	
M2.6-4	4.0	1.5	4.3	#1	M2.6x0.45P	
M2.6-5	5.0	1.5	4.3	#1	M2.6x0.45P	
M2.6-6	6.0	1.5	4.3	#1	M2.6x0.45P	
M2.6-8	8.0	1.5	4.3	#1	M2.6x0.45P	
M2.6-10	10.0	1.5	4.3	#1	M2.6x0.45P	
M3-4	4.0	2.1	5.5	#1	M3x0.5P	1000
M3-5-1	5.0	1.4	5.5	#1	M3x0.5P	
M3-5	5.0	2.1	5.5	#1	M3x0.5P	
M3-6	6.0	2.1	5.5	#1	M3x0.5P	
M3-8	8.0	2.1	5.5	#1	M3x0.5P	
M3-10	10.0	2.1	5.5	#1	M3x0.5P	
M3-12	12.0	2.1	5.5	#1	M3x0.5P	
M3-14	14.0	2.1	5.5	#1	M3x0.5P	
M3-15	15.0	2.1	5.5	#1	M3x0.5P	
M3-17	17.0	2.1	5.5	#1	M3x0.5P	
M3-18	18.0	2.1	5.5	#1	M3x0.5P	

Part No.	A	B	C	PH	Thread	Package
M3-20	20.0	2.1	5.5	#1	M3x0.5P	1000
M3-25	25.0	2.1	5.5	#1	M3x0.5P	
M3-30	30.0	2.1	5.5	#1	M3x0.5P	
M4-5	5.0	2.5	7.0	#2	M4x0.7P	
M4-6	6.0	2.5	7.0	#2	M4x0.7P	
M4-8	8.0	2.5	7.0	#2	M4x0.7P	
M4-8L	8.0	3.0	8.0	#1	M4x0.7P	
M4-10	10.0	2.5	7.0	#2	M4x0.7P	
M4-10L	10.0	3.1	8.0	#1	M4x0.7P	
M4-12	12.0	2.5	7.0	#2	M4x0.7P	
M4-14	14.0	2.5	7.0	#2	M4x0.7P	
M4-16	16.0	2.5	7.0	#2	M4x0.7P	
M4-20	20.0	2.5	7.0	#2	M4x0.7P	
M4-25	25.0	2.5	7.0	#2	M4x0.7P	
M4-30	30.0	2.5	7.0	#2	M4x0.7P	
M4-35	35.0	2.5	7.0	#2	M4x0.7P	
M5-10	10.0	3.6	9.1	#1	M5x0.8P	2000
M5-16	16.0	3.6	9.1	#1	M5x0.8P	
M5-20	20.0	3.6	9.1	#1	M5x0.8P	
R440-4S	4.75	1.8	5.8	#1	4-40 UNC	1000
R440-6	6.4	2.4	5.2	#1	4-40 UNC	
R440-7	7.0	2.4	5.2	#1	4-40 UNC	
R440-8	8.0	2.4	5.2	#1	4-40 UNC	
R440-9	9.5	2.4	5.2	#1	4-40 UNC	2000
R440-12	12.7	2.4	5.2	#1	4-40 UNC	
R440-15	15.5	2.4	5.2	#1	4-40 UNC	
R440-19	19.0	2.4	5.2	#1	4-40 UNC	
R632-6	6.35	2.5	6.7	#2	6-32 UNC	1000
R632-8	8.0	2.5	6.7	#2	6-32 UNC	
R632-9	9.5	2.5	6.7	#2	6-32 UNC	
R632-12	12.7	2.5	6.7	#2	6-32 UNC	
R632-15	15.9	2.5	6.7	#2	6-32 UNC	2000
R632-19	19.1	2.5	6.7	#2	6-32 UNC	



- Material: Nylon 66 (UL)/PC (UL)
- Flame Class: 94V-2/94V-0
- Color: Natural/Black
- Unit: mm

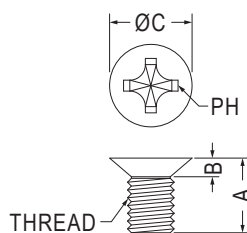

Part No.	A	B	C	PH	Thread	Package
M2-4.5F	4.5	1.2	3.6	#0	M2x0.4P	2000
M2-5.5F	5.5	1.2	3.6	#0	M2x0.4P	
M2-6.5F	6.5	1.2	3.6	#0	M2x0.4P	
M2-7.5F	7.5	1.2	3.6	#0	M2x0.4P	
M2-8.5F	8.5	1.2	3.6	#0	M2x0.4P	
M2.5-6F	6.0	1.5	4.6	#1	M2.5x0.45P	
M2.5-8F	8.0	1.5	4.6	#1	M2.5x0.45P	

塑膠螺絲 SCREW

用途：用於固定需絕緣之零件，重量輕，耐腐蝕。



- Material: Nylon 66 (UL)/PC (UL)
- Flame Class: 94V-2/94V-0
- Color: Natural/Black
- Unit: mm

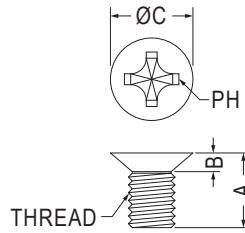

Part No.	A	B	C	PH	Thread	Package
M3-8F	8.0	1.6	5.6	#1	M3x0.5P	1000
M3-10F	10.0	1.6	5.6	#1	M3x0.5P	
M3-12F	12.0	1.6	5.6	#1	M3x0.5P	
M3-14F	14.0	1.6	5.6	#1	M3x0.5P	
M4-8F	8.0	2.0	7.6	#1	M4x0.7P	
M4-10F	10.0	2.0	7.6	#1	M4x0.7P	
M4-12F	12.0	2.0	7.6	#1	M4x0.7P	
M4-14F	14.0	2.0	7.6	#1	M4x0.7P	
M4-16F	16.0	2.0	7.6	#1	M4x0.7P	
M4-18F	18.0	2.7	7.65	#1	M4x0.7P	
M5-10F	10.0	2.5	9.1	#2	M5x0.8P	
M5-15F	14.8	2.5	9.1	#2	M5x0.8P	
M6-25F	25.0	2.0	8.4	#2	M6x1.0P	

Part No.	A	B	C	PH	Thread	Package
M3-4.2F	4.2	1.7	6.0	#1	M3x0.5P	2000
M3-5F	4.8	1.2	5.3	#2	M3x0.5P	1000
M3-5.3F	5.0	1.6	5.3	#1	M3x0.5P	
M3-6F	6.0	1.6	5.6	#1	M3x0.5P	



- Material: PEEK (UL)
- Flame Class: 94V-0
- Color: Natural
- Unit: mm

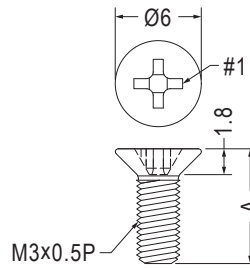

Part No.	A	Package
M3-8FPK	8.0	1000
M3-10FPK	10.0	
M3-12FPK	12.0	
M3-14FPK	14.0	
M3-15FPK	15.0	
M3-17FPK	17.0	
M3-18FPK	18.0	
M3-20FPK	20.0	
M3-25FPK	25.0	
M3-30FPK	30.0	

Part No.	A	Package
M3-4FPK	4.0	1000
M3-5FPK	5.0	
M3-6FPK	6.0	



- Material: Nylon 66 (UL)
- Flame Class: 94V-2/94V-0
- Color: Natural/Black
- Unit: mm

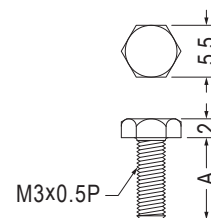
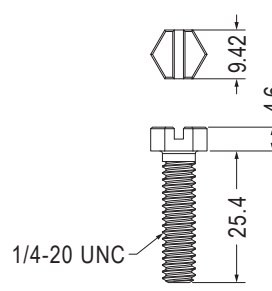
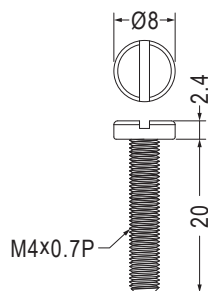

Part No.	Package
MIL4-20	1000

Part No.	Package
MI420-25.4	1000

Part No.	A	Package
STM3-4	4.0	2000
STM3-6	6.0	
STM3-8	8.0	
STM3-10	10.0	
STM3-12	12.0	

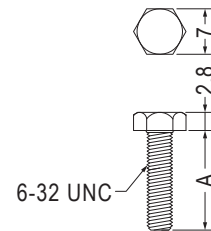
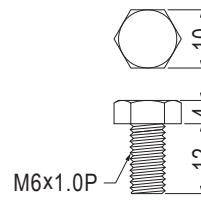
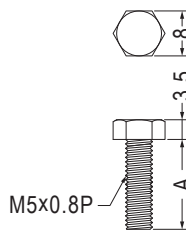
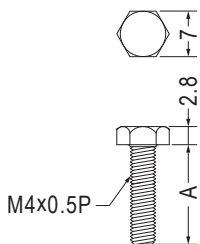

Part No.	A	Package
STM4-6	6.0	2000
STM4-8	8.0	
STM4-10	10.0	
STM4-12	12.0	

Part No.	A	Package
STM5-16	16.0	1000
STM5-25	25.0	

Part No.	Package
STM6-12	2000

Part No.	A	Package
STM632-6	6.35	2000
STM632-8	8.0	
STM632-9	9.5	
STM632-12	12.7	

塑膠螺絲 SCREW

用途：用於固定需絕緣之零件，重量輕，耐腐蝕。



- Material: Nylon 66 (UL)
- Flame Class: 94V-2/94V-0
- Color: Natural/Black
- Unit: mm

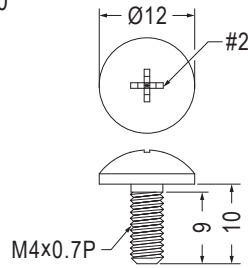

Part No.	Package
M4-9NBD	1000

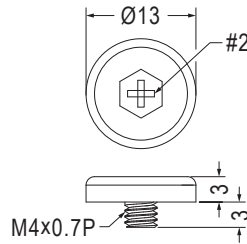

Part No.	Package
MRL4-3	1000

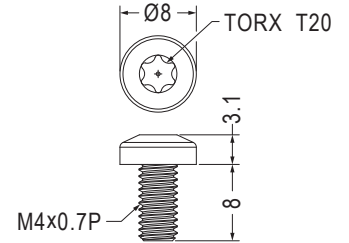

- Material: PC (UL)
- Flame Class: 94V-2
- Color: Transparent

Part No.	Package
MRT-8	1000



- Material: PC (UL)
- Flame Class: 94V-2/94V-0
- Color: Transparent
- Unit: mm

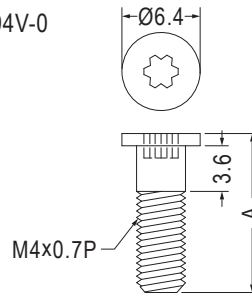

Part No.	A	Package
MR4-9.5	9.5	1000
MR4-12	12.0	
MR4-20	20.0	



- Head Material: Nylon 66 (UL)+GF
- Head Flame Class: 94V-0
- Color: Black
- Unit: mm

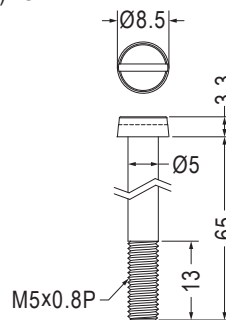

Part No.	Package
M5A-65	250



- Material: PC (UL)
- Flame Class: 94V-2/94V-0
- Color: Transparent
- Unit: mm

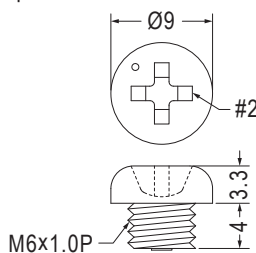

Part No.	Package
M6-4	1000

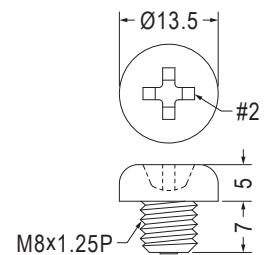

- Material: Nylon 66 (UL)
- Color: Natural/Black

Part No.	Package
M8-7	1000

塑膠螺絲 SCREW

用途：用於固定需絕緣之零件，重量輕，耐腐蝕。



- Material: PC (UL)
- Flame Class: 94V-2/94V-0
- Color: Transparent
- Unit: mm

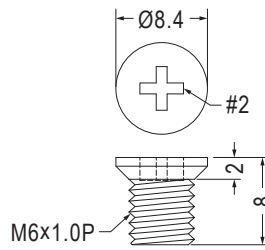

Part No.	Package
M6-8F	500

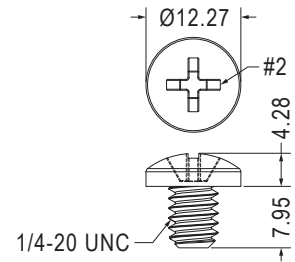

- Material: POM
- Color: Black

Part No.	Package
RU1420-8	500



- Material: PE
- Color: Black
- Unit: mm

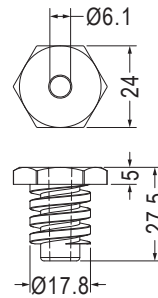

Part No.	Package
EM-528	500



- Material: PC (UL)
- Flame Class: 94V-2/94V-0
- Color: Black
- Unit: mm

用途：用於汽車點煙器插座之固定。

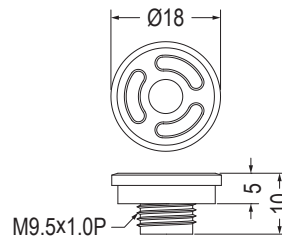

Part No.	Package
ATFF-1	1000



- Material: PP (UL)
- Flame Class: 94HB
- Color: Black/White
- Unit: mm

用途：用於零件、紙張及PC板之固定。

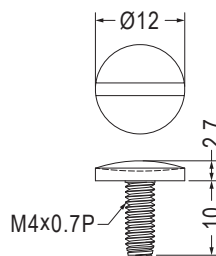

Part No.	Package
KSM-1A	1000

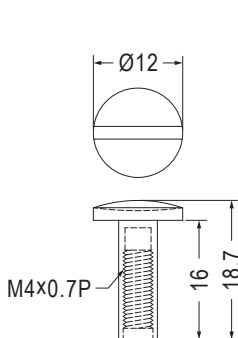

Part No.	Package
KSM-1B	1000

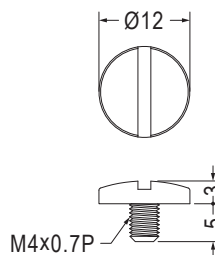

- Material: PE
- Color: Black/White

Part No.	Package
KSM4-5M	1000

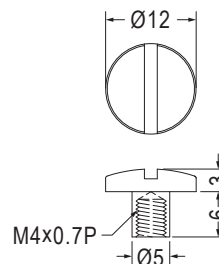

- Material: PE
- Color: Black/White

Part No.	Package
KSM4-6F	1000

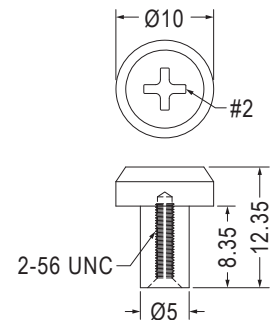

- Material: Nylon 66 (UL)
- Flame Class: 94V-2/94V-0
- Color: Natural/Black

Part No.	Package
KSC256-8.4F	2000

塑膠螺絲 SCREW

用途：用於固定需絕緣之零件，重量輕，耐腐蝕。



- Material: Nylon 66 (UL)
- Flame Class: 94V-2/94V-0
- Color: Natural/Black
- Unit: mm

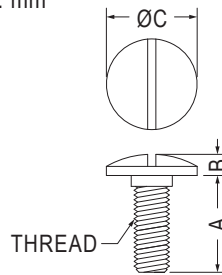

Part No.	A	B	C	Thread	Package
MIA6-16	16.0	3.5	15.0	M6x1.0P	1000
MIA8-20	20.0	5.0	18.5	M8x1.25P	500



- Material: PC (UL)
- Flame Class: 94V-2/94V-0
- Color: Transparent
- Unit: mm

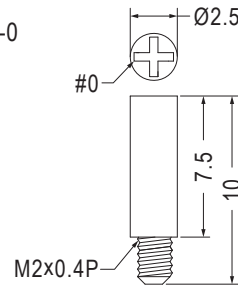

Part No.	Package
MUS2-10	2000



- Head Material: PC+ABS (UL)
- Head Flame Class: 94V-2/94V-0
- Color: Black
- Unit: mm

用途：螺絲式，固定於機殼。

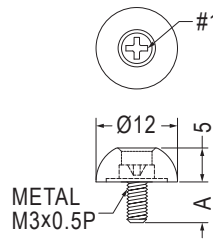

Part No.	A	Package
GPEA3-6BN	6.0	500
GPEA3-8BN	8.0	

止付螺絲 SET SCREW

用途：做為螺絲之固定，絕緣，重量輕，耐腐蝕。



- Material: PC (UL)
- Flame Class: 94V-2/94V-0
- Color: Black
- Unit: mm

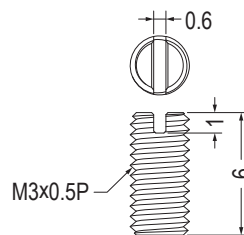

Part No.	Package
THRI3-6	2000

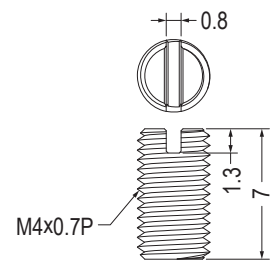

Part No.	Package
THRI4-7	2000



- Material: Nylon 66 (UL)
- Flame Class: 94V-2/94V-0
- Color: Natural/Black
- Unit: mm

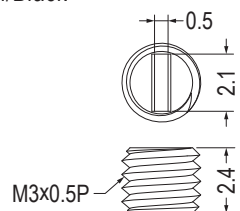

Part No.	Package
THRIA3-2.4	2000

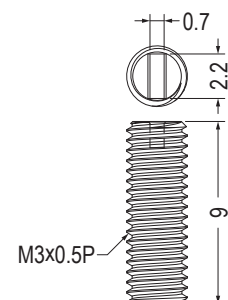

Part No.	Package
THRIA3-9	1000

NEW

止付螺絲 SET SCREW

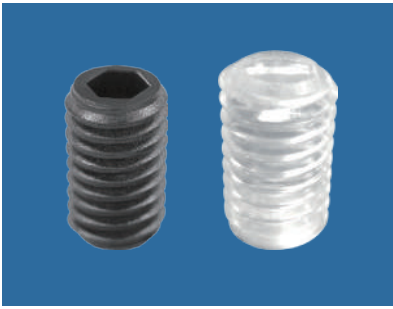

- Material: Nylon 66 (UL)
- Flame Class: 94V-2/94V-0
- Color: Natural/Black
- Unit: mm

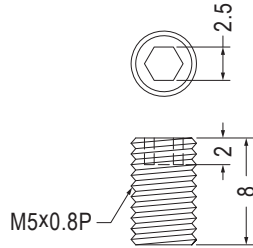

Part No.	Package
THR5-8	2000

用途：做為螺絲之固定，絕緣，重量輕，耐腐蝕。

- Material: PC (UL)
- Flame Class: 94V-2/94V-0
- Color: Transparent
- Unit: mm

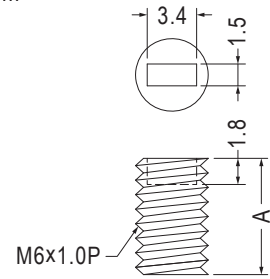

Part No.	A	Package
THRI6-6	6.0	2000
THRI6-8	8.0	
THRI6-10	10.0	

手轉螺母 HAND SPIN NUT



- Material: PC+ABS (UL)
- Flame Class: 94V-2/94V-0
- Color: Black
- Unit: mm

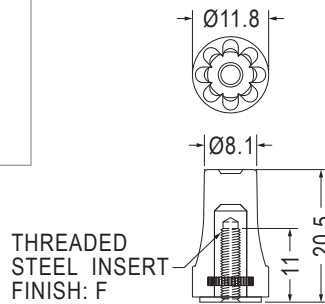

用途：用於外殼及零組件之固定，可手轉，不需工具，方便不脫落。

Part No.	F	Thread	Package
GPM3-20	Zinc Plated	M3x0.5P	1000
GPM4-20	Nickel Plated	M4x0.7P	
GPM632-20	Zinc Plated Nickel Plated	6-32 UNC	

手轉螺絲 THUMB SCREW



- Cap Material: Nylon 66 (UL)
- Body Material: PC+ABS (UL)
- Screw Material: Steel
- Cap Flame Class: 94V-2
- Body Flame Class: 94V-0
- Screw Finish: Zinc Plated
- Color: Black
- Unit: mm

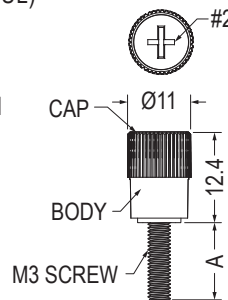

用途：用於外殼及零組件之固定，可手轉，不需工具，方便不脫落。

Part No.	A	Package
HASW3-8	5.0	1000
HASW3-9	6.0	
HASW3-13	10.0	
HASW3-18	15.0	
HASW3-23	20.0	
HASW3-28	25.0	
HASW3-33	30.0	

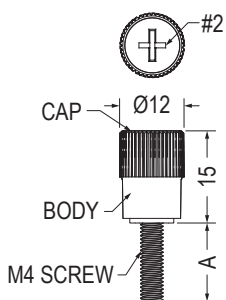

Part No.	A	Package
HASW4-8	5.0	500
HASW4-13	10.0	
HASW4-18	15.0	
HASW4-23	20.0	
HASW4-28	25.0	
HASW4-33	30.0	

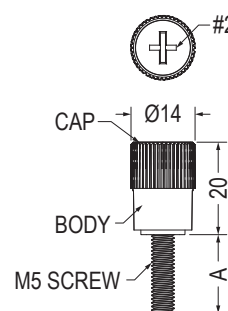

Part No.	A	Package
HASW5-10	7.0	250
HASW5-15	12.0	
HASW5-20	17.0	
HASW5-25	22.0	
HASW5-30	27.0	
HASW5-35	32.0	
HASW5-40	37.0	
HASW5-45	42.0	
HASW5-50	47.0	

手轉螺絲 THUMB SCREW

用途：螺絲式，固定於機殼。



- Head Material: PC+ABS (UL)
- Head Flame Class: 94V-2/94V-0
- Color: Black
- Unit: mm

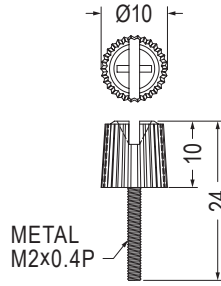

Part No.	Package
GPE2-24	1000

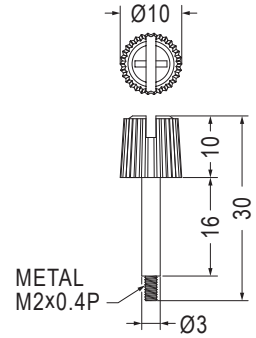

Part No.	Package
GPE2-30	1000



- Plastic Material: PP (UL)
- Flame Class: 94HB
- Color: Black
- Unit: mm

用途：做為螺絲之固定，絕緣，重量輕，耐腐蝕。

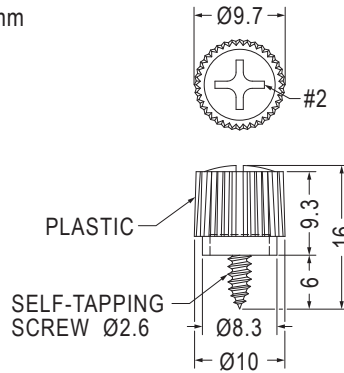

Part No.	Package
GPE2.6-6	1000



- Material: PC+ABS (UL)
- Flame Class: 94V-2/94V-0
- Color: Black
- Unit: mm

用途：螺絲式，固定於機殼。

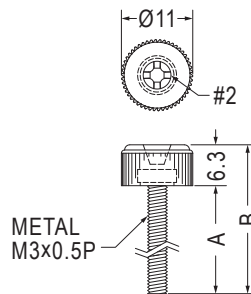

Part No.	A	B	Package
GPE3-5.5	5.5	11.8	1000
GPE3-8	8.0	14.3	
GPE3-15	15.0	21.3	
GPE3-23	23.0	29.3	

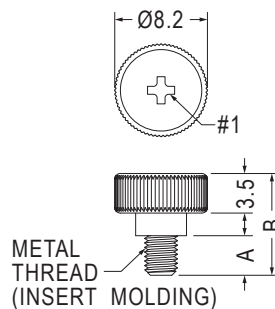

Part No.	A	B	Thread	Package
★GPEE2-3	3.0	8.5	M2x0.4P	1000
GPEE3-3.5	3.5	9.0	M3x0.5P	

手轉螺絲 THUMB SCREW

用途：用於外殼及零組件之固定，可手轉，不需工具，方便不脫落。



- Head Material: PC (UL)
- Head Flame Class: 94V-2/94V-0
- Color: Black
- Unit: mm

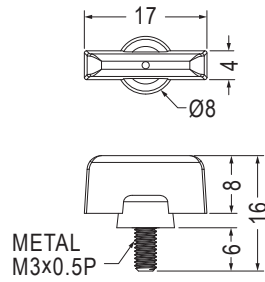

Part No.	Package
GPED3-6	500



- Head Material: PC+ABS (UL)
- Head Flame Class: 94V-2/94V-0
- Color: Natural/Black
- Unit: mm

用途：螺絲式，固定於機殼。

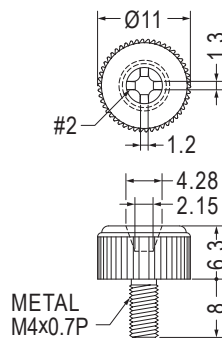

Part No.	Package
GPE4-8	500



- Head Material: ABS (UL)
- Head Flame Class: 94HB
- Color: Natural/Black
- Unit: mm

用途：用於外殼及零組件之固定，可手轉，不需工具，方便不脫落。

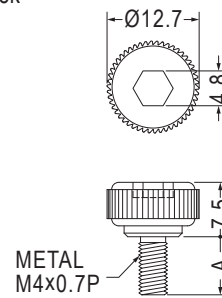

Part No.	A	Package
GPE4-8L	8.0	500
GPE4-12L	12.0	



- Head Material: PP (UL)
- Head Flame Class: 94HB
- Color: Black
- Unit: mm

用途：用於外殼及零組件之固定，可手轉，不需工具，方便不脫落。

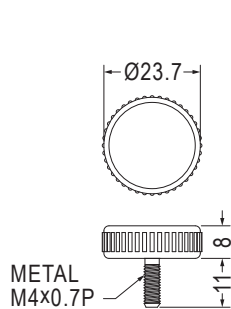

Part No.	Package
GPE4-12-1	200

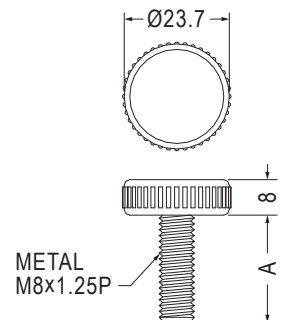

Part No.	A	Package
GPE8-21	13.0	100
GPE8-32	24.7	

手轉螺絲 THUMB SCREW

用途：螺絲式，固定於機殼。



- Head Material: ABS (UL)
- Head Flame Class: 94HB
- Color: Black
- Unit: mm

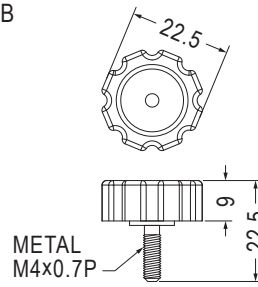

Part No.	Package
GPE4-13.5	250

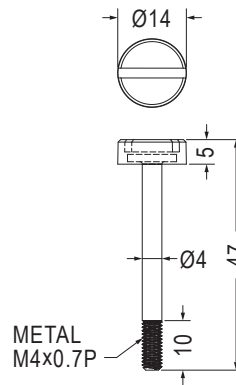

Part No.	Package
GPE4-42	250

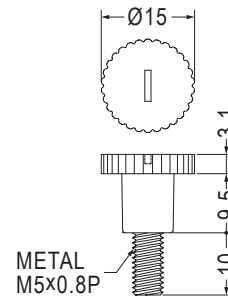

Part No.	Package
GPE5-20	500



- Head Material: PC (UL)
- Head Flame Class: 94V-2/94V-0
- Color: Black
- Unit: mm

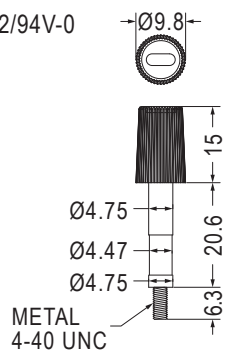

Part No.	Package
GPE44-1	500



- Head Material: PP (UL)
- Head Flame Class: 94HB
- Color: Black
- Unit: mm

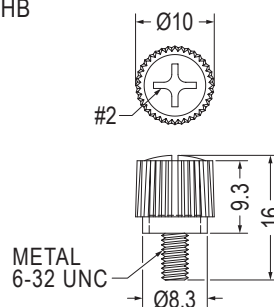

Part No.	Package
GPE632-6	500

手轉螺絲 THUMB SCREW

用途：螺絲式，固定於機殼。



- Head Material: ABS (UL)
- Head Flame Class: 94HB
- Color: Natural/Black
- Unit: mm

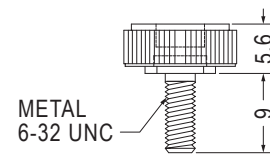
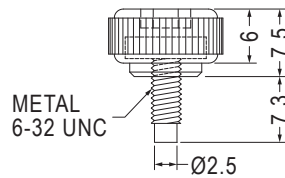
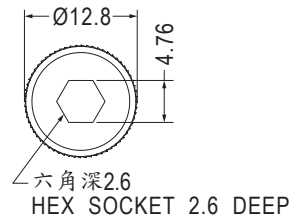
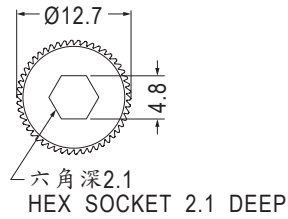

Part No.	Package
GPE632-5	500

Part No.	Package
GPE632-9	500



- Head Material: PC+ABS (UL)
- Head Flame Class: 94V-2/94V-0
- Color: Black
- Unit: mm

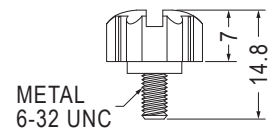
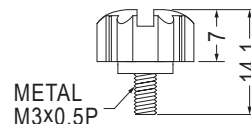
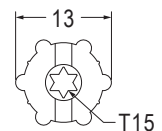
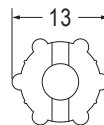

Part No.	Package
GPR3-5.5	1000

Part No.	Package
GPR632-6	500

旋鈕螺絲 SCREW

用途：用於固定需絕緣之零件，重量輕，耐腐蝕，可用手旋轉，一般用於電腦外殼之固定。

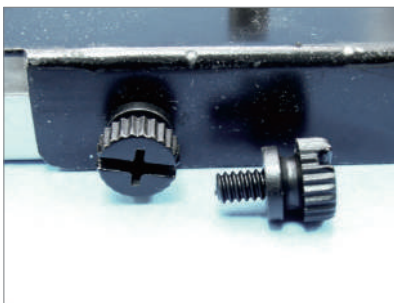

- Material: Nylon 66 (UL)
- Flame Class: 94V-2/94V-0
- Color: Natural/Black
- Unit: mm

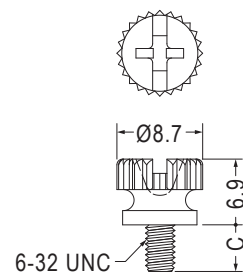
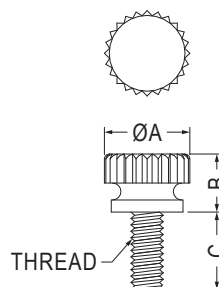

Part No.	A	B	C	Thread	Package
SUS632	9.0	6.9	9.8	6-32 UNC	1000
SUS832	10.6	7.2	9.6	8-32 UNC	

Part No.	C	Package
RSUS632	5.0	1000
RSUS632-6	6.0	

螺絲墊片 SCREW WASHER

用途：可配合螺絲使用之墊片。



- Material: Nylon 66 (UL)
- Flame Class: 94V-2/94V-0
- Color: Natural/Black
- Unit: mm

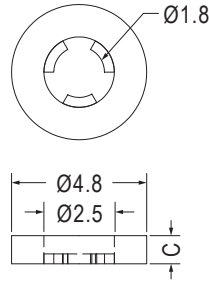

RECOMMENDED
MATING SCREW: M2

Part No.	C	Package
KWS2-05	0.5	2000
KWS2-08	0.8	
KWS2-10	1.0	
KWS2-15	1.5	
KWS2-20	2.0	
KWS2-25	2.5	

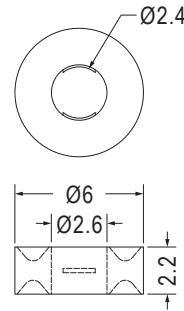
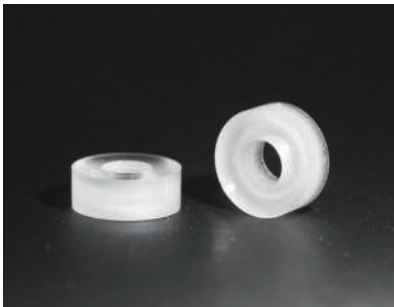

Part No.	Package
KWSB2.5-2.2	2000



- Material: Nylon 66 (UL)/PE/LDPE
- Flame Class: 94V-2/94V-0
- Color: Natural/Black
- Unit: mm

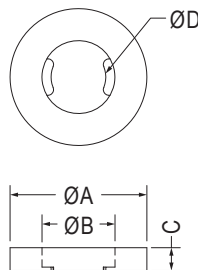

RECOMMENDED
MATING SCREW: S

Part No.	A	B	C	D	S	Package
KWSP2-1	5.0	2.7	1.0	2.2	M2.6	2000
KWSP2-1.1	6.5	2.7	1.1	2.2		
KWSP2-1.5	5.0	2.7	1.5	2.2		
KWSP-2.5	5.0	2.7	1.0	2.0	M3	1000
KWSP-2.6	6.0	3.2	1.0	2.4		
KWSP-9	18.0	10.5	1.5	8.7	M9	1000



- Material: Nylon 66 (UL)/Nylon 6 (UL)/PE
- Natural: 94HB/94V-2/94V-0
- Color: Natural/Black
- Unit: mm

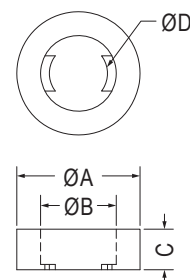

RECOMMENDED
MATING SCREW: S

Part No.	A	B	C	D	S	Package
KWSP3-1.5	9.0	3.2	1.5	2.6	M3	1000
KWSP4-1.4	12.0	4.3	1.4	3.3	M4	2000
KWSP4-2.3	7.0	4.3	2.3	3.3		
KWSP5-1	10.0	5.3	1.0	4.1	M5	
KWSP5-15	15.0	5.3	1.5	4.3		
KWSP6-1.6	12.0	6.4	1.6	5.0	M6	
KWSP6-2	18.0	6.4	2.0	5.15		
KWSP10-2.5	21.0	10.5	2.5	8.9	M10	1000

螺絲墊片 SCREW WASHER

用途：可配合螺絲使用之墊片。



- Material: PP (UL)
- Flame Class: 94HB
- Color: Black
- Unit: mm

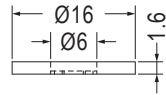
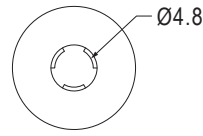

RECOMMENDED
MATING SCREW: M6

Part No.	Package
KWS5-1.6	2000

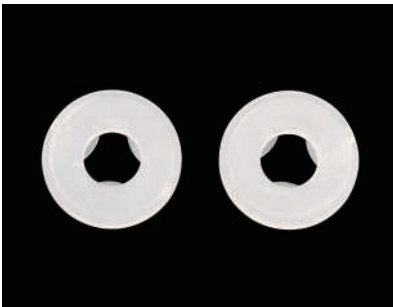

- Material: PE
- Color: Natural
- Unit: mm

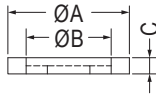
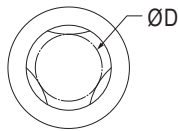

RECOMMENDED
MATING SCREW: S

Part No.	A	B	C	D	S	Package
KWS3-0.8	8.0	3.2	0.8	2.5	M3	2000
KWS5-1	20.0	5.3	1.0	4.2	M5	
KWS6-1.6	12.0	6.4	1.6	5.2	M6	
KWS8-1.6	12.0	8.4	1.6	6.6	M8	
KWS12-2.5	27.0	12.8	2.5	10.4	M12	500



- Material: Nylon 66 (UL)
- Flame Class: 94V-2/94V-0
- Color: Orange
- Unit: mm

用途：可配合M3螺絲使用之墊片。

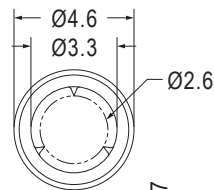

RECOMMENDED
MATING SCREW: M3

Part No.	Package
KWA3-0.7	1000



- Material: Nylon 6 (UL)
- Flame Class: 94HB
- Color: Natural
- Unit: mm

用途：可配合螺絲使用之墊片。

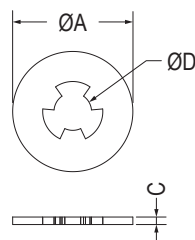

Part No.	A	C	D	Package
KYWS2-0.3	4.8	0.3	1.8	2000
KWS-2.6	4.8	0.5	2.2	
KWS-2.6-08	4.8	0.8	2.2	
KWS-2.6-1	4.8	1.0	2.2	
KYWS-3	8.0	0.5	2.5	

螺絲墊片 SCREW WASHER

用途：可配合螺絲使用之墊片。

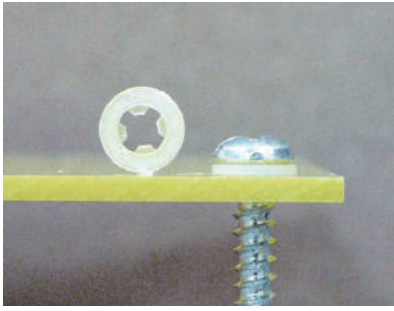

- Material: Nylon 66 (UL)
- Flame Class: 94V-2/94V-0
- Color: Natural/Black
- Unit: mm

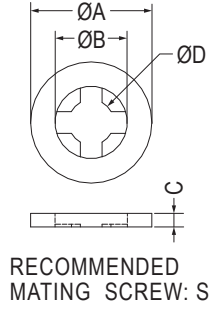

Part No.	A	B	C	D	S	Package
KWS-3S	5.0	4.0	0.6	2.5	M3	2000
KWS-3	6.7	4.0	0.8	2.5		
KWS-3-1.2	6.7	3.5	1.2	2.5		
KWS-3.8	9.92	5.97	0.81	3.86	M4	
★KWS-3.8L	10.0	8.0	0.81	3.86		
KWS-4	8.0	5.0	1.0	3.3	M5	
KWS-4.6	15.0	9.5	0.9	4.6		
KWS-5S	11.45	7.1	0.85	4.6		
KWS-5	15.0	9.5	0.9	5.0		
KWS-5L	16.0	7.03	1.6	4.5		
KWS-8	8.5	5.8	0.9	4.4	M6	
KWS-6	15.0	9.5	0.9	5.8		
KWS-632	8.3	5.0	0.8	3.2	6-32 UNC	
KWS-632-1.6	8.35	4.96	1.64	3.15		
KWS832-0.8	9.91	5.97	0.81	3.43	8-32 NUC	

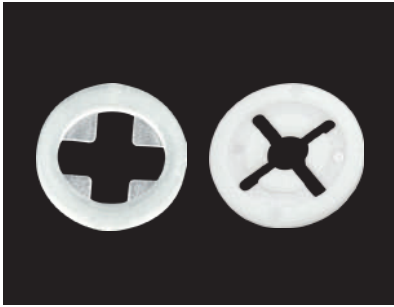

- Material: Nylon 66 (UL)
- Flame Class: 94V-2/94V-0
- Color: Natural/Black
- Unit: mm

用途：可配合螺絲使用，墊片不脫落。

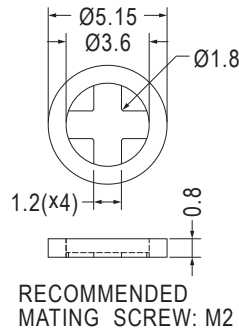

Part No.	Package
KWS-2	2000

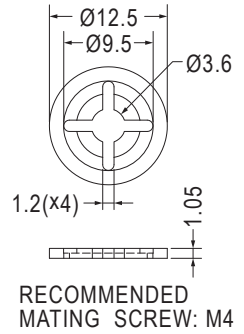

Part No.	Package
KWS-3.6	2000

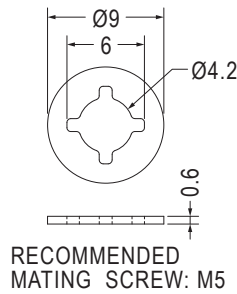

Part No.	Package
KWS-4.2-0.6	2000

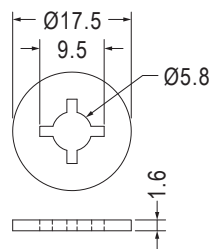
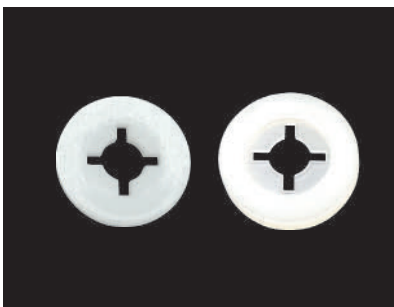

Part No.	Package
KWS-6L	2000

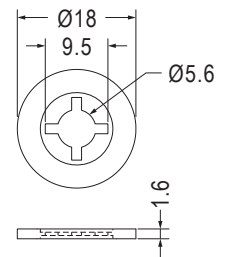

Part No.	Package
KWS-6-1	2000

華司 WASHER

用途：做為零件之墊片。

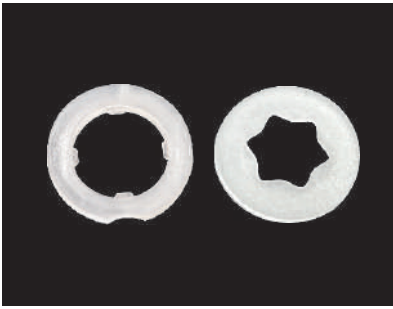

- Material: Nylon 66 (UL)
- Flame Class: 94V-2/94V-0
- Color: Natural/Black
- Unit: mm

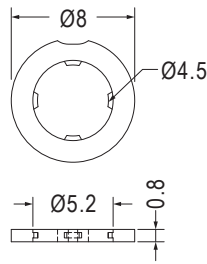

Part No.	Package
KWSA-5	1000

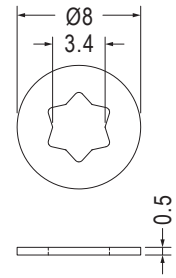

Part No.	Package
WSW8-3.4-0.5	1000

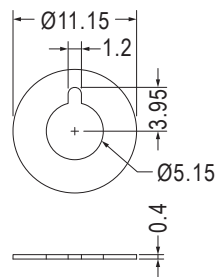

Part No.	Package
COCF-1	1000



- Material: POM (UL)
- Flame Class: 94HB
- Color: Natural/Black
- Unit: mm

用途：可配合螺絲使用之墊片。

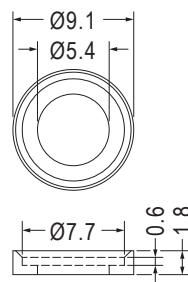

Part No.	Package
WSUA-1	2000

- Material: PE
- Color: Black

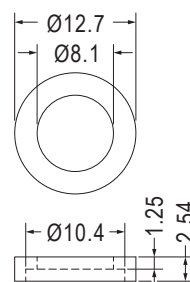

Part No.	Package
WSUA-2	2000

墊片 WASHER

用途：做為零件之墊片。



- Material: PE
- Color: Black
- Unit: mm

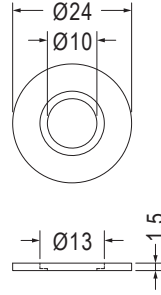

Part No.	Package
WSUC-1	1000



- Material: Nylon 66 (UL)
- Flame Class: 94V-2/94V-0
- Color: Black
- Unit: mm

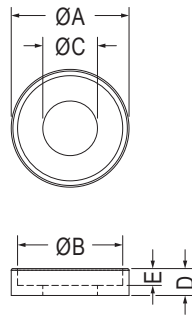

Part No.	A	B	C	D	E	Package
WSUC-2	14.0	12.5	6.5	3.2	2.0	2000
WSUC-3	12.45	9.8	4.45	3.55	2.3	

華司 WASHER

用途：可配合螺絲使用之墊片。

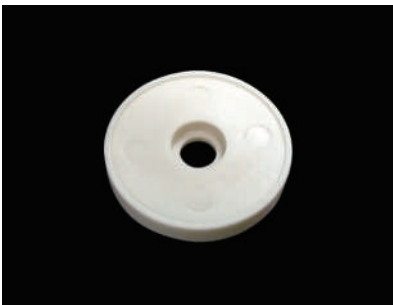

- Material: ABS (UL)
- Flame Class: 94HB
- Color: Natural
- Unit: mm

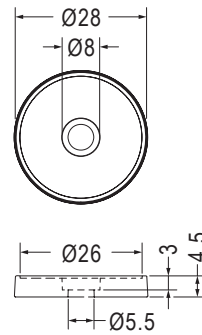

Part No.	Package
WSU-1	1000

零件墊片 WASHER

用途：做為零件之墊片。



- Material: Nylon 66 (UL)
- Flame Class: 94V-2/94V-0
- Color: Natural/Black
- Unit: mm

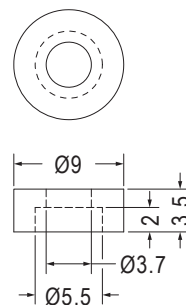

Part No.	Package
TWC-17	2000

螺絲墊片 SCREW WASHER

用途：可配合M3.5螺絲使用之墊片。



- Material: Nylon 66 (UL)
- Flame Class: 94V-2/94V-0
- Color: Natural/Black
- Unit: mm

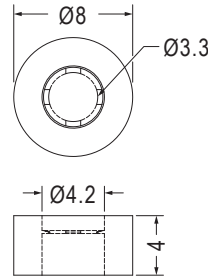

Part No.	Package
KWS4-4	1000

零件墊片 WASHER

用途：做為零件之墊片。



- Material: Nylon 66 (UL)
- Flame Class: 94V-2/94V-0
- Color: Natural/Black
- Unit: mm

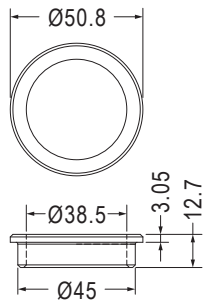

Part No.	Package
TWC-14	1000

滾輪 ROLLER

用途：用於機櫃當滾輪使用。



- Material: PC (UL)/PBT (UL)/POM/
Nylon 66 (UL)
- Flame Class: 94V-2/94V-0
- Color: Black
- Unit: mm

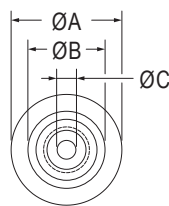

【 UPC-1, UPC-3 】

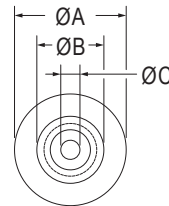

【 UPC-4 】

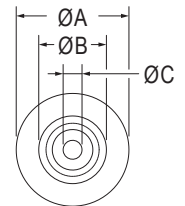

【 UPC-5 】

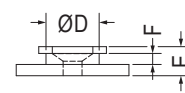
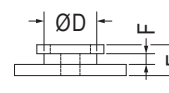
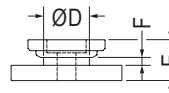

Part No.	A	B	C	D	E	F	Material	Package
UPC-1	25.4	17.67	4.3	11.07	9.36	1.79	PC	1000
UPC-3	25.4	17.7	4.3	11.0	9.4	1.95		
UPC-4	25.0	15.0	4.3	11.8	6.9	2.4	PBT	
	24.2	14.7	4.1	11.4	6.6	2.4	POM	
UPC-5	25.0	15.0	4.2	11.8	6.45	2.45	NYLON 66	

零件墊片 WASHER

用途：做為零件之墊片。



- Material: PC+ABS (UL)
- Flame Class: 94V-2/94V-0
- Color: Natural/Black
- Unit: mm

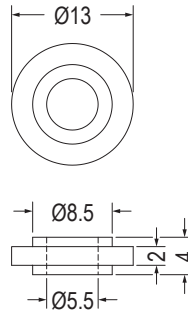

Part No.	Package
TWC-4	2000

墊片 WASHER

用途：做為零件之墊片。



- Material: PC (UL)
- Flame Class: 94V-2/94V-0
- Color: Natural/Black
- Unit: mm

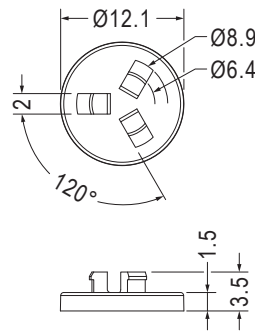

Part No.	Package
WSG-1	2000

零件墊片 WASHER

用途：螺絲墊片，耐熱性良好。



- Material: Nylon 66 (UL)
- Flame Class: 94V-2/94V-0
- Color: Natural/Black
- Unit: mm

- Material: POM (UL)
- Flame Class: 94HB

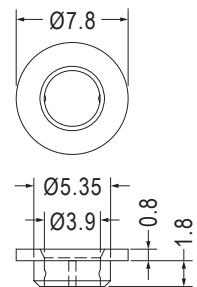
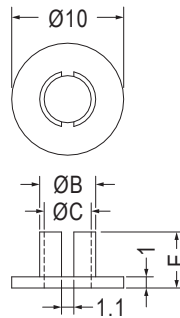

Part No.	B	C	E	Package
TWU-1	5.0	4.2	5.0	2000
TWU-3	6.0	5.0	6.0	

• 可配合M4螺絲

Part No.	Package
TWU-2	2000

絕緣柱 ROUND SPACER

用途：用於零件之絕緣使用。



- Material: Nylon 66 (UL)
- Flame Class: 94V-2/94V-0
- Color: Natural/Black
- Unit: mm

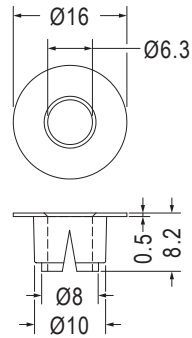

Part No.	Package
GLIN-10	1000

墊片 WASHER

用途：螺絲墊片耐熱性良好。



- Material: Nylon 66 (UL)
- Flame Class: 94V-2/94V-0
- Color: Natural/Black
- Unit: mm

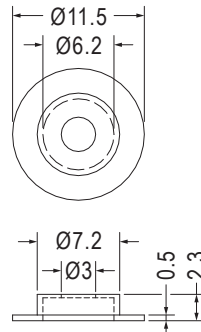

Part No.	Package
WSC-1	2000

華司 WASHER

用途：做為螺絲之墊片。



- Material: PC (UL)
- Flame Class: 94V-2/94V-0
- Color: Natural
- Unit: mm

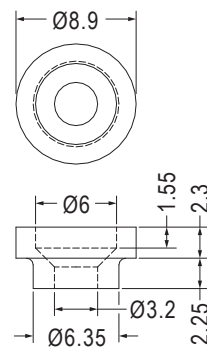

Part No.	Package
WSF-3	2000



- Material: Nylon 66 (UL)
- Flame Class: 94V-2/94V-0
- Color: Natural/Black
- Unit: mm

用途：可配合螺絲使用之墊片。

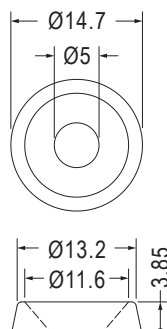

Part No.	Package
WSU-515	2000

螺絲墊片 SCREW WASHER

用途：可配合螺絲使用之墊片。



- Material: Nylon 6 (UL)/Nylon 66 (UL)
- Flame Class: 94V-2/94V-0
- Color: Black
- Unit: mm

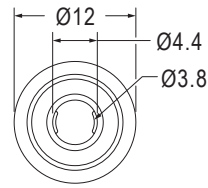

RECOMMENDED
MATING SCREW: M4

Part No.	Package
WSUB-1	1000

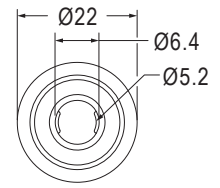

RECOMMENDED
MATING SCREW: M6

Part No.	Package
WSUB-4	500

零件墊片 WASHER

用途：做為零件之墊片。



- Material: Nylon 66 (UL)
- Flame Class: 94V-2/94V-0
- Color: Natural/Black
- Unit: mm

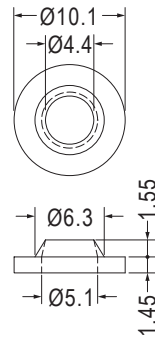

Part No.	Package
TWC-1	2000

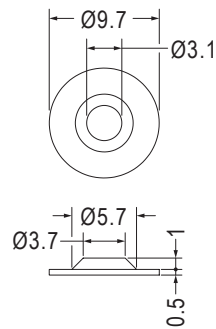

Part No.	Package
TWC-19	1000



- Material: PPS (UL)
- Flame Class: 94V-0
- Color: Natural(Brown)/Black
- Unit: mm

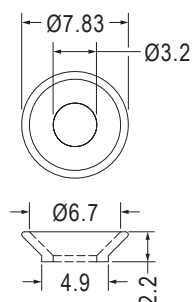

Part No.	Package
TWC-15	2000

零件墊片 WASHER

用途：做為零件之墊片。

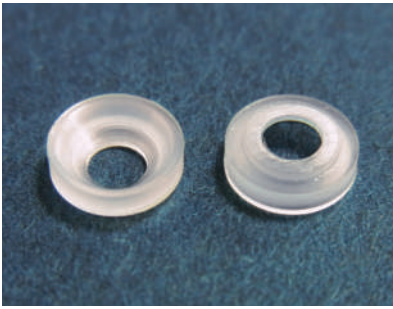

- Material: Nylon 66 (UL)
- Flame Class: 94V-2/94V-0
- Color: Natural/Black
- Unit: mm

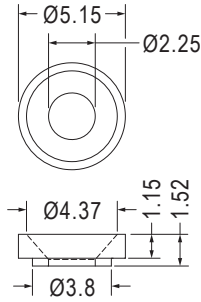

Part No.	Package
TWC-8	1000

絕緣柱 ROUND SPACER

用途：用於零件之絕緣使用。



- Material: PC (UL)
- Flame Class: 94V-2
- Color: Natural
- Unit: mm

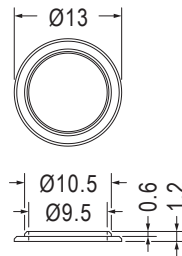

Part No.	Package
UPD-1	1000

- Material: Nylon 66 (UL)
- Flame Class: 94V-2/94V-0
- Color: Natural/Black
- Unit: mm

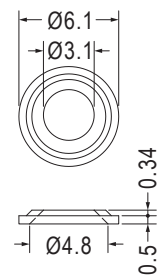

Part No.	Package
TWC-2	2000

墊片 WASHER

用途：做為零件之墊片。

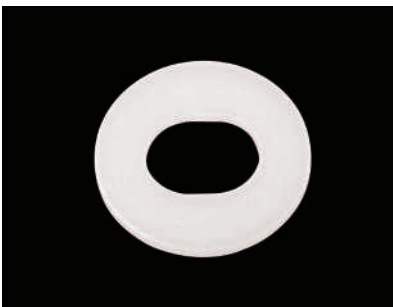

- Material: POM(UL)
- Flame Class: 94HB
- Color: Natural
- Unit: mm

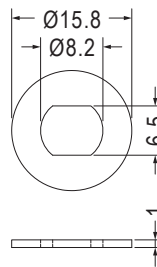

Part No.	Package
WSH-1	1000

- Material: Nylon 6 (UL)
- Flame Class: 94HB
- Color: Natural
- Unit: mm

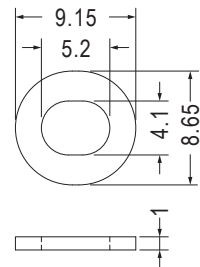

Part No.	Package
WSR9.1-8.6-1	1000



- Material: Nylon 66 (UL)
- Flame Class: 94V-2/94V-0
- Color: Natural/Black
- Unit: mm

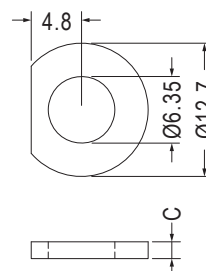

Part No.	C	Package
WSA6-1.5	1.58	1000
WSA6-6.3	6.35	

尼龍華司 WASHER

用途：做為零件之墊片。

可依客戶需求訂製不同材質。
Different materials available per request.



- Material: Nylon 66/Nylon 6 (UL)/PE/PBT (UL)/PP(UL)/POM (UL)
- Color: Natural/Black
- Unit: mm

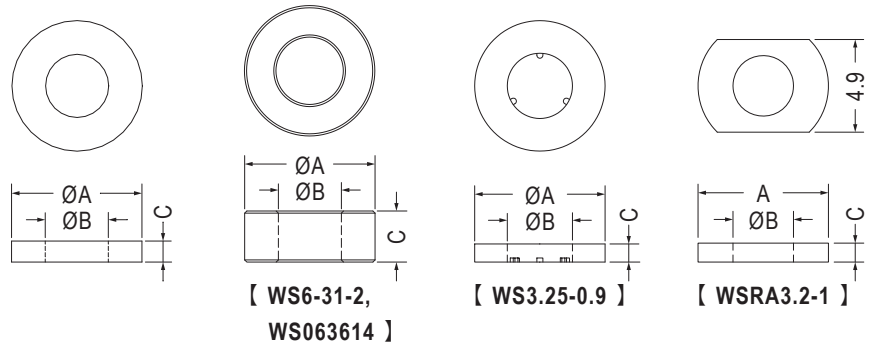

Part No.	A	B	C
WS1.7-0.5	3.5	1.7	0.5
WS3.5-1810	3.5	1.8	1.0
WS3-2-1	3.7	2.2	1.0
WS2.2-12	3.7	2.2	1.2
WS2.5-0.5S	4.0	2.5	0.5
WS2.6-2	4.0	2.6	2.0
WS4-3.1-1	4.0	3.1	1.0
WS4-3-12	4.1	3.1	1.2
WS42-19-05	4.2	1.9	0.5
WS45-2-08	4.5	2.0	0.8
WS2.1-0.8	4.5	2.1	0.8
WS4.5-2.1-09	4.5	2.1	0.9
WS4.5-2.1-1.1	4.5	2.1	1.1
WS4.5-2.1-1.15	4.5	2.1	1.1
WS4.5-2.1-1.2	4.5	2.1	1.2
WS4.5-2.1-1.3	4.5	2.1	1.3
WS452117	4.5	2.1	1.7
WS4.5-2.1-1.8	4.5	2.1	1.8
WS2.5-0.5	4.5	2.5	0.5
WS-4529	4.5	2.9	1.2
WS4.9-3715	4.9	3.7	1.5
WS2.1-2	5.0	2.1	2.0
WS5-2.1-1	5.0	2.1	1.0
WS2.5-10	5.0	2.5	1.1
WS2.5-13	5.0	2.5	1.3
WS5-3-2.5	5.0	3.0	2.5
WS5-3.1-1	5.0	3.1	1.0
WS3.1-1.8	5.0	3.1	1.8
WS3.1-2	5.0	3.1	2.0
WS53205	5.0	3.2	0.5
WS5-2-0.5	5.5	2.3	0.5
WS3.2-2.8	5.5	3.2	2.8
WS3-5-1.5	5.6	3.1	1.5
WS3.7-0.3	5.6	3.73	0.3
WS6-23-08	6.0	2.3	0.8
WS2-0.5	6.0	2.5	0.5
WS6-2.7-3	6.0	2.7	3.0
WS6-31-2	6.0	2.9	2.35
WS6-3008	6.0	3.0	0.8
WS6-31-05	6.0	3.1	0.5
WS3-1.5	6.0	3.1	1.5

Part No.	A	B	C
WS3-2	6.0	3.1	2.0
WS3-3.4	6.0	3.1	3.4
WS6-3.2-0.5	6.0	3.2	0.5
★WS3.2-0.8	6.0	3.2	0.8
WS6-3.2-1	6.0	3.2	1.0
WS063214	6.0	3.2	1.4
WS063614	6.0	3.6	1.4
WS6-3.8-1	6.0	3.8	1.0
WS6-38-15	6.0	3.8	1.5
WS4-0.6	6.0	4.0	0.6
WS-6451	6.0	4.5	1.0
WS6.1-1.2	6.1	3.7	1.2
WS63-42-15	6.3	4.2	1.55
WS6352125	6.35	2.3	2.5
WS63530512	6.35	3.05	1.27
WS6.3-3.1-1.5	6.35	3.18	1.58
WS6.5-3.1-20	6.5	3.1	2.0
WS3.25-0.9	6.5	3.25	0.9
WS3.8-0.5	6.5	3.8	0.5
WS4-1.6	6.5	4.0	1.65
WS4-2.2	6.5	4.0	2.2
WS4-2.5	6.5	4.0	2.5
WS4-1	6.8	4.2	1.0
WSRA3.2-1	6.9	3.2	1.0
WS2.2-0.5	7.0	2.2	0.5
WS3-1	7.0	3.0	1.0
WS7-3-0.8	7.0	3.0	0.8
WS7-3.1-0.5N	7.0	3.1	0.5
WS7-3.2-0.5	7.0	3.2	0.5
WS7-3.3-2	7.0	3.3	2.0
WS7-3.6-3.2	7.0	3.6	3.2
WS4.2-1.5	7.0	4.2	1.5
WS4.3-2	7.0	4.3	2.0
WS4.3-2.3	7.0	4.3	2.3
WS4.6-0.6	7.0	4.6	0.6
WS7-5-1.6	7.0	5.0	1.6
WS3.7-0.5	7.1	3.7	0.5
WS71316	7.11	3.05	1.57
WS7.1-55158	7.13	5.53	1.58
WS7.4-4.5-0.5	7.4	4.5	0.5
WS4.7-0.8	7.5	4.7	0.8

Part No.	A	B	C
WS3.5-0.5	7.5	3.5	0.5
WS-7543	7.5	4.3	0.65
WS5.3-0.7	7.7	5.3	0.7
WS8-2-2	8.0	2.0	2.0
★WS2.6-0.5	8.0	2.6	0.45
WS3-5	8.0	3.1	0.5
WS3-8	8.0	3.1	0.8
WS3-10	8.0	3.1	1.0
WS3-15	8.0	3.1	1.5
WS3-20	8.0	3.1	2.0
WS8-3.6-08	8.0	3.6	0.8
WS8-3.6-25	8.0	3.6	2.5
WS8-4-2	8.0	4.0	2.0
WS4-5	8.0	4.1	0.5
WS4-8	8.0	4.1	0.8
WS4-10	8.0	4.1	1.0
WS4-15	8.0	4.1	1.5
WS4-20	8.0	4.1	2.0
WS8-4.2-2.8	8.0	4.2	2.85
WS8-4.3-0.5	8.0	4.3	0.5
WS4-3	8.0	4.6	0.3
WS8-5-1	8.0	5.0	1.0
WS5-5	8.0	5.0	5.0
WS8-5.1-2	8.0	5.1	2.0
WS5-0.5	8.0	5.2	0.5
WS5.2-0.5	8.0	5.2	0.5
WS855075	8.0	5.5	0.75
WS-855	8.0	5.5	1.5
WS8-55-18	8.0	5.5	1.8
WS5.6-1	8.3	5.65	1.0
WS6.1-1	8.3	6.1	1.0
WS8.6-4.1-1	8.65	4.1	1.0
WS2-1.5	8.8	2.0	1.5
WS2.5-1	9.0	2.5	1.0
WS3.2-0.5	9.0	3.2	0.5
WS9-4.3-1	9.0	4.3	1.0
WS4.5-0.5	9.0	4.5	0.5
WS9-55-075	9.0	5.5	0.75
WS9-6.2-1.2	9.0	6.2	1.2
WS9-6.7-2	9.0	6.7	2.0
★WS4.4-0.8	9.6	4.4	0.8

尼龍華司 WASHER

用途：做為零件之墊片。



- Material: Nylon 66/Nylon 6 (UL)/PE/PBT (UL)/PP(UL)/POM (UL)
- Color: Natural/Black
- Unit: mm

可依客戶需求訂製不同材質。
Different materials available per request.

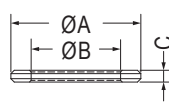
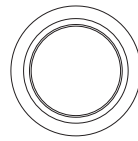
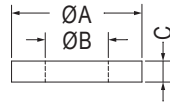
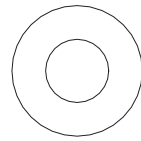

【 WS5.3-0.7 】

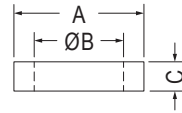
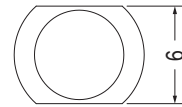

【 WS8-55-18 】

Part No.	A	B	C
WS96-44-08	9.6	4.4	0.8
WS5.6-0.7	9.6	5.6	0.7
WS5.6-2.3	9.6	5.6	2.3
WS3.1-10-1	10.0	3.1	1.0
WS10-4.3-4	10.0	4.3	4.0
WS4.5-1.5	10.0	4.5	1.5
WS10-5124	10.0	5.1	2.4
WS10-5.2-0.8	10.0	5.2	0.8
WS5-1	10.0	5.2	1.0
WS5-2	10.0	5.2	2.0
WS5.5-0.8	10.0	5.5	0.8
WS10-5710	10.0	5.7	1.0
WS10-5720	10.0	5.7	2.0
WS6.1-1.6	10.0	6.1	1.6
WS-1064	10.0	6.4	0.8
WS106428	10.0	6.4	2.8
WS8-1.6	10.0	8.0	1.6
WS6.35-1.6	10.15	6.35	1.6
WS1015	10.2	5.2	1.5
★WS8.35-1	10.5	8.35	1.0
WS11-4.4-0.8	10.9	4.4	0.8
WS5.2111.5	11.0	5.2	1.5
WS11785	11.0	7.0	0.8
WS7.2-1.2	11.0	7.2	1.2
WS7.2-2.5	11.0	7.2	2.5
WS11-5-1.3	11.3	5.4	1.3
WS7.6-0.5	11.3	7.6	0.5
WS115-35-4	11.5	3.5	4.0
WS3.2-1	11.6	3.2	1.0
WS7.6-1	11.6	7.6	1.0
WS4.3-1	12.0	4.3	1.0
WS12-5-2	12.0	5.0	2.0
WS5.2-0.8	12.0	5.2	0.8
WS5.3-2	12.0	5.3	2.0
WS12-64-1.4	12.0	6.4	1.4
WS1276415	12.7	6.48	1.52
WS1276420	12.7	6.48	2.0
WS1276565	12.7	6.5	6.5
WS12779215	12.7	7.9	1.57
★WS12.7-9.7-1.6	12.7	9.78	1.57
WS6-0.8	12.8	6.4	0.8

Part No.	A	B	C
WS6-2	12.8	6.4	2.0
WS6.48-3	12.8	6.48	3.0
WS8.1-1.6	13.0	8.1	1.6
WS12.5-1	13.4	12.5	1.0
WS-148	14.0	8.0	1.2
WS-1482	14.0	8.0	2.0
WS8.1-0.8	14.0	8.1	0.8
WS14263515	14.2	6.35	1.5
WS14-11-1	14.7	11.5	1.0
WS4.3-1.5	15.0	4.3	1.5
WS7-1	15.0	7.1	1.0
WS10-5	15.0	10.3	5.0
WS6.7-0.65	15.5	6.7	0.65
WS7.1-1.5	15.8	7.1	1.5
WS15.8-9.1-1.7	15.8	9.1	1.65
WS6-1.6	16.0	6.0	1.6
WS8.4-1.6	16.0	8.4	1.6
WS16-96-15	16.0	9.6	1.5
WS10-0.8	16.0	10.0	0.8
WS10-1.5	16.0	10.0	1.5
WS16-11-32	16.0	11.4	3.2
WS10.3-1	16.2	10.3	1.0
WS10.3-1.5	16.2	10.3	1.5
WS10.1-2	17.0	10.1	2.0
WS18-6.4-1.6	18.0	6.4	1.6
WS8-1	18.0	8.2	1.0
WS8.4-1	18.0	8.4	1.0
WS8.4-1.5	18.0	8.4	1.5
WS19-11-1.6	19.0	11.0	1.6
WS12.1-2.5	19.0	12.1	2.5
WS19-14-3.2	19.05	14.35	3.18
WS5-1.2	19.5	5.0	1.2
WS20-6.5-2	20.0	6.5	2.0
WS17-1.3	20.2	17.8	1.3
WS14-3.6	20.3	14.5	3.65
WS14-4	20.3	14.5	4.0
WS10-3	20.7	10.0	3.0
WS21-10-2	21.0	10.5	2.0
WS19.1-0.5	21.8	19.1	0.5
WS221350	22.0	13.0	5.0
WS13-2	23.0	13.0	2.0

Part No.	A	B	C
WS8-3	24.0	8.05	3.0
WS16.1-2.5	24.0	16.1	2.5
WS16.1-3	24.0	16.1	3.0
WS25-10	25.0	14.5	10.0
WS29-17-3	29.5	17.2	3.0
WS30-6-1.5	30.0	6.0	1.5
WS6.3-2	30.0	6.3	2.0
WS20.1-3.5	30.0	20.1	3.5
WS33-28-15	33.5	28.5	1.5
WS22.1-4	34.75	22.1	4.0
WS34-26-1	34.8	26.2	1.0
WS24.1-4	36.0	24.1	4.0
WS2905U	38.0	29.0	0.5
WS27.1-4.5	39.0	27.1	4.5
WS421905	42.0	19.0	0.5
WS40-1.5	45.5	40.0	1.5

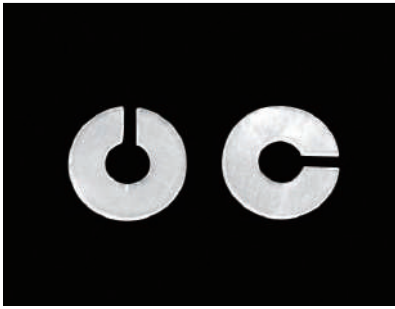

- Material: Nylon 66 (UL)/Nylon 6 (UL)/PC (UL)/PP (UL)
- Flame Class: 94HB/94V-2/94V-0
- Color: Natural/Black
- Unit: mm

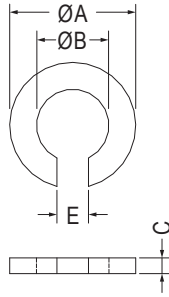

Part No.	A	B	C	E	Package
COC2-0.5	4.0	2.3	0.5	1.0	2000
COC3-1	6.0	3.0	1.0	1.0	
COC5-4	8.0	5.0	4.0	2.5	
★COC12.6-1.5	18.0	12.6	1.5	1.0	1000



- Material: Nylon 66(UL)
- Flame Class: 94V-2/94V-0
- Color: Natural/Black
- Unit: mm

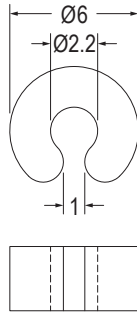

Part No.	Package
COCA2.2-3	2000

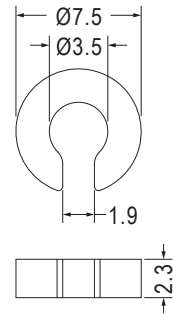

Part No.	Package
COCA3.5-2.3	2000



- Material: Nylon 66 (UL)
- Flame Class: 94V-2/94V-0
- Color: Natural/Black
- Unit: mm

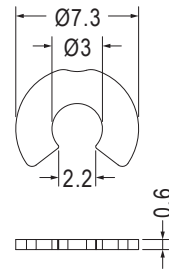

Part No.	Package
COCA3-0.6	1000

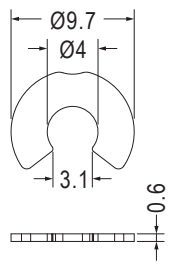

Part No.	Package
COCA4-0.6	1000



- Material: POM (UL)
- Flame Class: 94HB
- Color: Black
- Unit: mm

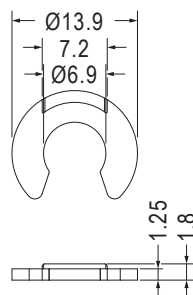

Part No.	Package
COCE-1	1000