

DIM.	TOL
L ≤ 10	±0.2
10 < L ≤ 30	±0.3
30 < L ≤ 50	±0.5
50 < L ≤ 100	±0.7
100 < L ≤ 250	±1.2
ABOVE 250	±1.5

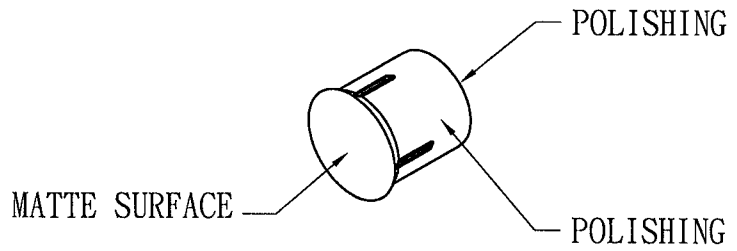
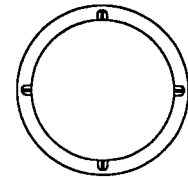
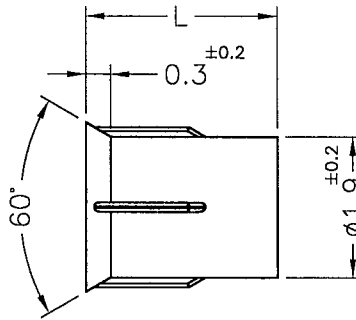
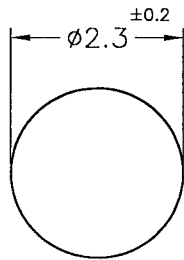

MOUNTING HOLE: $\phi 1.98^{\pm 0.05}$
 (RECOMMEND FOR REFERENCE ONLY)

PART NO.	L
LEMB2-2V0-F	2.0
LEMB2-2.5V0-F	2.5
LEMB2-3V0-F	3.0
LEMB2-3.2V0-F	3.2
LEMB2-4V0-F	4.0
LEMB2-4.8V0-F	4.8
LEMB2-5V0-F	5.0
LEMB2-6V0-F	6.0
LEMB2-6.4V0-F	6.4
LEMB2-7V0-F	7.0
LEMB2-8V0-F	8.0
LEMB2-9V0-F	9.0
LEMB2-10V0-F	10.0
LEMB2-20V0-F	20.0

NOTE: MADE OF EQUIVALENT MATERIAL.
 均可使用同等材質.

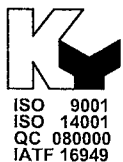

康揚企業股份有限公司
 KANG YANG HARDWARE ENTERPRISE CO., LTD.
 康揚塑膠(東莞)有限公司
 KANG YANG PLASTIC(DONG GUAN)CO.,LTD.
 康哲電腦配件(吳江)有限公司
 KANG CHE COMPUTER COMPONENTS(WUJIANG)CO.,LTD.

康揚塑膠五金(泰國)有限公司
 บริษัท คง หยาง ฮาร์ดแวร์ (ไทยแลนด์) จำกัด
 KANG YANG HARDWARE (THAILAND) CO., LTD.
 康揚越南有限公司
 CÔNG TY TNHH KANG YANG VIỆT NAM
 KANG YANG VIETNAM CO., LTD.

PROPRIETARY AND CONFIDENTIAL THE INFORMATION CONTAINED IN THIS DRAWING IS THE SOLE PROPERTY OF KANG YANG HARDWARE ENTERPRISE CO. ANY REPRODUCTION IN PART OR AS A WHOLE WITHOUT THE WRITTEN PERMISSION OF KANG YANG HARDWARE ENTERPRISE CO. IS PROHIBITED. DO NOT SCALE DRAWING	DATE	TITLE	DWG. NO.	PART NO.	
	2016.08.05	LIGHT PIPE	LEMB2-HV0-F	SEE ABOVE	
	DRAWN Summer	MATERIAL PC		SIZE A4	SPEC. DWG
	CHECKED Yuping	COLOR TRANSPARENT	FINISH	SCALE: 8:1	
APPROVED Kang	UNLESS OTHERWISE SPECIFIED TOLERANCE: SEE ABOVE		SHEET 1 OF 1		