

Patented Product
專利產品

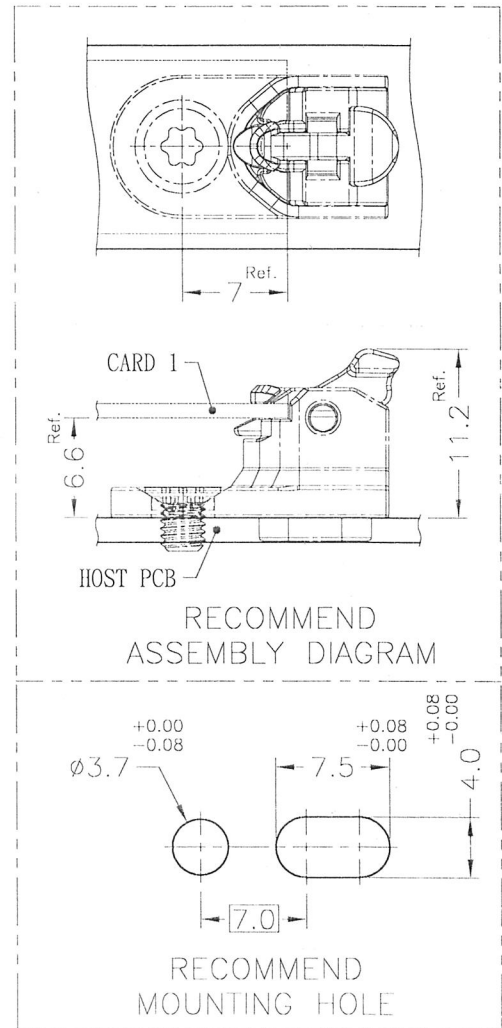

PART NAME	MATERIAL	COLOR	FINISH
BODY	NYLON66 UL94V-0	BLACK	
LATCH	NYLON66 UL94V-0+GF	BLUE	
SCREW	CARBON STEEL		ZINC PLATED

- NOTE: 1. MADE OF EQUIVALENT MATERIAL.
均可使用同等材質.
2. SLIGHT DEFORMED IS NORMAL STATUS.
輕微變形為正常現象.
3. NOTE: SHRINKING IS NORMAL STATUS.
內縮為正常現象.
4. THE COLOR BATCH TEST REPORT IS ONLY FOR FIRST LOT TEST.
色母環保檢測報告, 僅提供原始測試報告.

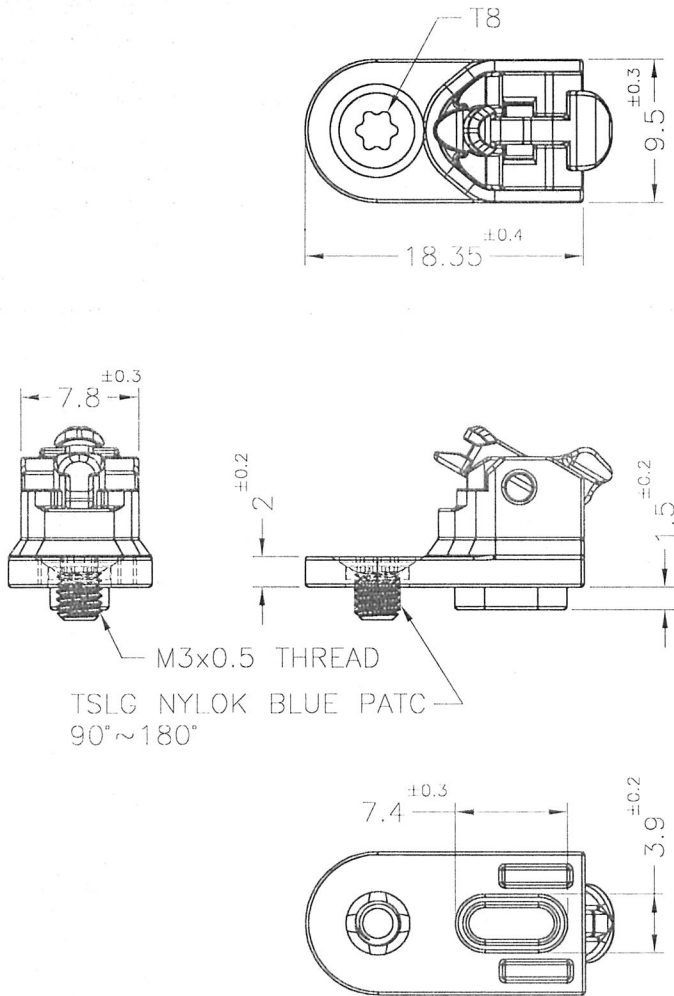
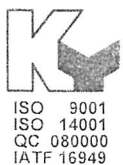

康揚企業股份有限公司
KANG YANG HARDWARE ENTERPRISE CO., LTD.
康揚塑膠(東莞)有限公司
KANG YANG PLASTIC(DONG GUAN)CO.,LTD.
康哲電腦配件(吳江)有限公司
KANG CHE COMPUTER COMPONENTS(WUJIANG)CO.,LTD.

康揚塑膠五金(泰國)有限公司
บริษัท หงษ์ ยาง ฮาร์ดแวร์ (ไทยแลนด์) จำกัด
KANG YANG HARDWARE (THAILAND) CO., LTD.
康揚越南有限公司
CÔNG TY TNHH KANG YANG VIỆT NAM
KANG YANG VIETNAM CO., LTD.

PROPRIETARY AND CONFIDENTIAL THE INFORMATION CONTAINED IN THIS DRAWING IS THE SOLE PROPERTY OF KANG YANG HARDWARE ENTERPRISE CO. ANY REPRODUCTION IN PART OR AS A WHOLE WITHOUT THE WRITTEN PERMISSION OF KANG YANG HARDWARE ENTERPRISE CO. IS PROHIBITED. DO NOT SCALE DRAWING	DATE	2024.06.18	TITLE	LATCH SPACER SUPPORT	DWG. NO.	ULCOI-11F	PART NO.	ULCOI-11V0F1	
	DRAWN	<i>H.W</i>	MATERIAL	SEE ABOVE	SIZE	A4	SPEC. DWG	REV	A
	CHECKED	<i>Kenny</i>	COLOR	SEE ABOVE	FINISH	SEE ABOVE	SCALE: 2:1	UNIT	mm
	APPROVED	<i>Kang</i>	UNLESS OTHERWISE SPECIFIED TOLERANCE:	SEE ABOVE					SHEET 1 OF 1